

# Agilent 82357A

USB/GPIB Interface Converter





# Contents

## 82357A USB/GPIB Interface Converter User's Guide

<b>Chapter 1 - Installing the 82357A .....</b>	<b>5</b>
Steps to Install the 82357A .....	7
Step 1: Before You Install the 82357A.....	8
Check Your Shipment .....	8
Check System Requirements .....	9
Step 2: Installing Agilent IO Libraries.....	10
Checking for Installed Agilent IO Libraries .....	10
Installing Full Agilent IO Libraries .....	11
Step 3: Connecting the 82357A.....	15
82357A Hardware Description .....	15
Connecting the 82357A to Your PC .....	16
Connecting the 82357A to a USB Hub .....	17
Observing Windows Plug and Play Manager Sequence (Windows XP Only) .....	19
Step 4: Configuring the 82357A.....	23
Setting 82357A Default Configuration .....	23
Setting 82357A Custom Configuration .....	25
Step 5: Connecting GPIB Instruments.....	28
Connecting a Single GPIB Instrument .....	28
Connecting Multiple GPIB Instruments .....	29
Step 6: Programming via the 82357A.....	30
Establishing Instrument Communication .....	30
Programming GPIB Instruments .....	31
<b>Chapter 2 - Using the 82357A .....</b>	<b>35</b>
Modes of Operation .....	37
Initial 82357A Operating States .....	37
Introduction to 82357A Operating Modes .....	38
Single 82357A Operation .....	39
Multiple 82357A Operation .....	40
SRQ Operation .....	40
Setting Configuration Parameters.....	41
Changing Configuration Parameters .....	41
Changing Modes of Operation .....	42
Setting Timeout Floor Values .....	42
Setting 82357A High-Performance Operation .....	43

<b>Chapter 3 - Troubleshooting the 82357A .....</b>	<b>45</b>
Troubleshooting Flowchart .....	47
Hardware Checks .....	49
Check USB Cables, USB Interface, Host PC .....	49
Reboot the PC .....	49
Check Device Manager .....	50
Software Installation Checks .....	51
Check Suspend/Resume Operation .....	51
Verify Agilent IO Libraries Installation .....	51
Verify 82357A USB Driver Installation .....	53
Software Configuration Checks .....	54
Checking IO Control Operation .....	54
Check USB Scanner .....	55
Check for usbscan.sys (Windows 98 SE Only) .....	56
Service/Support Information .....	58
82357A Service Information .....	58
Contacting Agilent .....	58
<b>Chapter 4 - 82357A User's Guide Information .....</b>	<b>59</b>
Guide Contents.....	61
Guide General Information .....	62
<b>Appendix A - 82357A Specifications .....</b>	<b>65</b>
Technical Specifications .....	67
Supplementary Information .....	68
<b>Appendix B - Using the Agilent IO Libraries .....</b>	<b>69</b>
Agilent IO Libraries Description .....	71
Agilent IO Libraries Components .....	71
Agilent IO Libraries Control .....	72
Program Groups Created .....	74
Using the Agilent IO Libraries CD.....	75
Installing Runtime Agilent IO Libraries .....	77
Installing Custom Agilent IO Libraries .....	81
<b>Index .....</b>	<b>91</b>

---

**Installing the 82357A**

---

---

## Installing the 82357A

This *Agilent 82357A USB/GPIB Interface Converter User's Guide* shows how to install and configure the Agilent 82357A USB/GPIB Interface Converter for PCs with Windows 98 (SE), Windows Me, Windows 2000, or Windows XP Professional operating systems.

### NOTE

*The 82357A USB/GPIB Interface Converter is supported ONLY for PCs with Windows 98 (Second Edition), Windows Me, Windows 2000, or Windows XP Professional operating systems.*

*These operating systems are specifically not supported :*

*Windows 98 First ("Gold") Edition*

*Windows 95*

*Windows NT 4.0 (OS does not support USB)*

*In case of difficulty in installing the 82357A, see Chapter 3 - Troubleshooting the 82357A. See Chapter 4 - 82357A User Guide Information for guide contents and general guide information*

This chapter shows suggested steps to install the 82357A, including:

- Steps to Install the 82357A
- Step 1: Before You Install the 82357A
- Step 2: Installing the Agilent IO Libraries
- Step 3: Connecting the 82357A
- Step 4: Configuring the 82357A
- Step 5: Connecting GPIB Instruments
- Step 6: Programming via the 82357A

---

## Steps to Install the 82357A

This figure shows a suggested sequence of steps to install and configure the 82357A and to communicate between your PC and GPIB instruments.

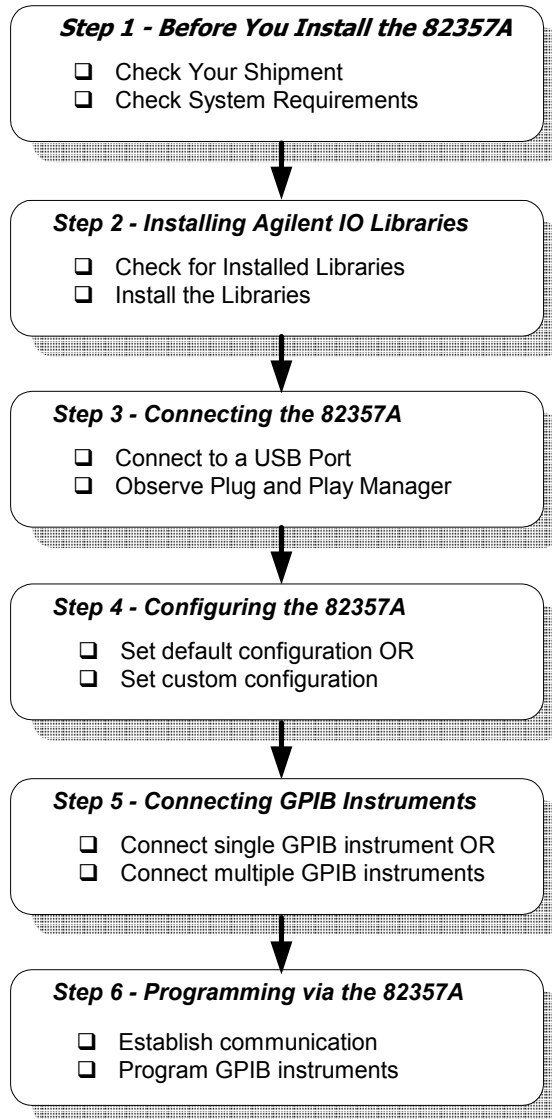

---

## Step 1: Before You Install the 82357A

Before you install the 82357A, you should:

- Check Your Shipment
- Check System Requirements

### Check Your Shipment

Your 82357A USB/GPIB Interface Converter shipment should include the items in the following figure. If any items are missing or damaged, keep the shipping materials and contact Agilent Technologies. See “*Contacting Agilent*” on page 58 for addresses and telephone numbers.

As you check the shipment items, verify that the 82357A Serial Number on the bottom of the 82357A matches the Serial Number shown on the Serial Number Label on the 82357A Kit Box and on the 82357A Certificate of Calibration. If the Serial Numbers do not match, contact Agilent. If all Serial Numbers match, you may want to record the Serial Number for future reference.

- *Agilent Technologies 82357A USB/GPIB Interface Converter*
- *Agilent IO Libraries for Instrument Control CD*
- *82357A USB/GPIB Interface Converter Getting Started Poster*
- *82357A USB/GPIB Interface Converter User's Guide*
- *82357A Certificate of Calibration*
- *82357A Registration Card*
- *Software License Agreement*

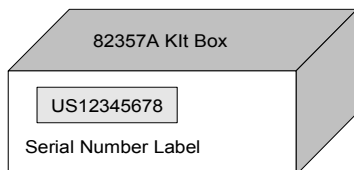

*Agilent IO Libraries for Instrument Control CD*

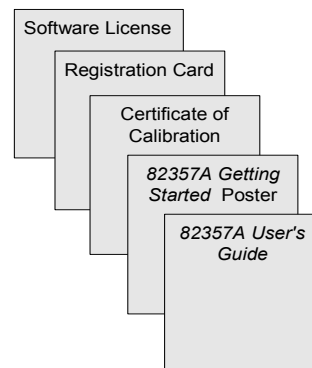



## Check System Requirements

Before you install the Agilent IO Libraries, you should verify that your system meets the **minimum** hardware and software requirements listed to install and use the Agilent IO Libraries. Adding additional RAM may improve overall system performance.

### NOTE

*The 82357A USB/GPIB Interface Converter is supported ONLY on Windows 98 Second Edition, Windows Me, Windows 2000, and Windows XP Professional.*

Item	Minimum Requirements
<b>Hardware Requirements</b>	
PC Operation/ Memory	Pentium 200 MHz operation and 32 MBytes RAM.
Hard Drive Space	At least 50 MBytes for VISA and SICL installation.
USB Port	At least one USB port (to connect 82357A)
<b>Software Requirements</b>	
Operating System	Windows 98 SE, Windows Me, Windows 2000, or Windows XP Professional.
Agilent IO Libraries	Agilent IO Libraries Version L.01.00 or greater.

### NOTE

*For Windows 98 Second Edition, you may need to install `usbscan.sys`, located on the Windows 98 CD-ROM. See “Check for `usbscan.sys` (Windows 98 SE Only)” in Chapter 3 - Troubleshooting the 82357A for details.*

---

## Step 2: Installing Agilent IO Libraries

This step shows how to perform a Full Installation of the Agilent IO Libraries, using default settings, including:

- Checking for Installed Agilent IO Libraries
- Installing Full Agilent IO Libraries

### NOTE

*See Appendix B - Using the Agilent IO Libraries for a description of the Agilent IO Libraries.*

## Checking for Installed Agilent IO Libraries

Before you begin installation, check for previously installed Agilent IO Libraries. If a version of the Agilent IO Libraries is installed on your PC, a blue IO icon may be displayed on the Windows taskbar (on the lower right-hand side of the screen).



- If the IO icon is displayed, click the icon and click **About Agilent IO Libraries Control** to display the version. The version must be L.01.00 or greater.
- If the IO icon is not displayed, a version may still be installed. To check this, click **Start | Programs** and look for the **Agilent IO Libraries** program group.
- If this group is displayed, click **Agilent IO Libraries | IO Control** to display the IO icon. Then, click the icon and click **About Agilent IO Libraries Control** to display the installed version (must be L.01.00 or greater).
- If neither the IO icon nor the Agilent IO Libraries program group is displayed, no Agilent IO Libraries are installed and you can use the steps in this chapter to install the libraries.

- If a version of the libraries less than L.01.00 is installed, do **not** use the steps in this chapter. Instead, use the steps in *Agilent IO Libraries Installation and Configuration Guide*.

## Installing Full Agilent IO Libraries

These steps show how to do a Full Installation of the Agilent IO Libraries in default directories and should be acceptable for most applications. To do a Runtime Installation or Custom Installation of the libraries or to install the libraries in a non-default directory, see *Appendix B - Using the Agilent IO Libraries*.

### NOTE

*A Full Installation allows you to run programs that use the Agilent IO Libraries to communicate with instruments and allows you to develop your own I/O programs. A Runtime Installation allows you to run existing programs on supported interfaces, but you cannot develop new programs that run on the Agilent IO Libraries.*

- 1 Turn the PC ON and, as required, install application software such as C/C++, VEE, etc. on your PC.
- 2 Make sure no 82357As are connected to your system. Then, insert the *Agilent IO Libraries for Instrument Control* CD into the CD-ROM drive and wait a few seconds for the application to run.
- 3 The installer should automatically start when the CD is inserted. If not, select **Start | Run** and browse to and select **Setup.exe** on your CD-ROM. Click **Open** to run the application.
- 4 The InstallShield® Wizard appears to begin the installation.

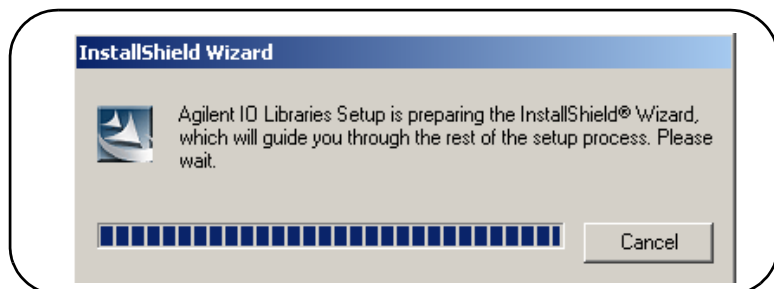

**Step 2: Installing Agilent IO Libraries**

- 5 After a few seconds, the **Title Screen** appears.

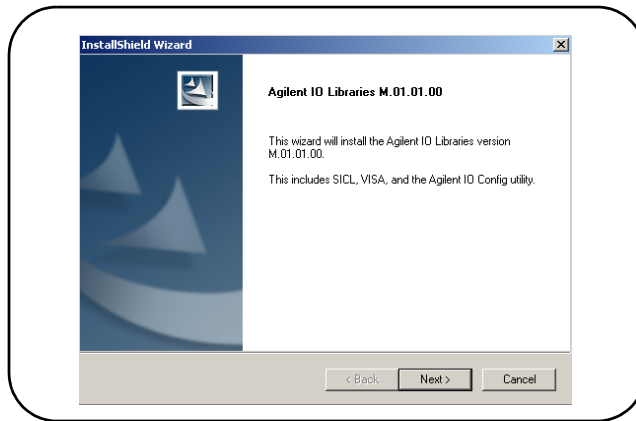

- 6 From the **Title Screen**, click **Next>** to go to the **License Agreement** screen and then click **Yes** to accept the license terms and to display the **Readme Information** screen.

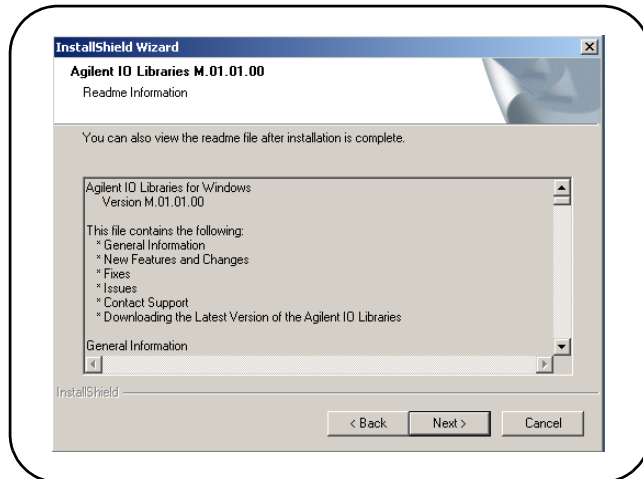

- 7 Scroll through the **Readme Information** screen to display the latest Agilent IO Libraries information. When finished with the **Readme Information** screen, click **Next>** to display the **Select the Installation Option** screen. Click the **Full Installation** box and **Next>**.

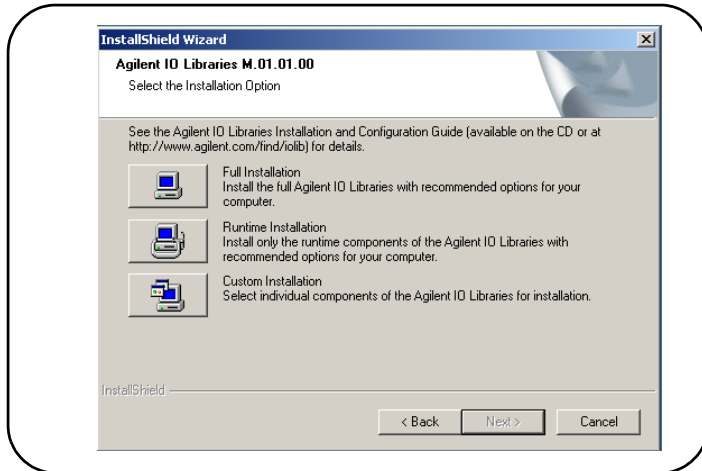

- 8 The **Current Settings** dialog box appears. This box shows the (default) paths in which SICL and VISA will be installed and the components that will be installed.

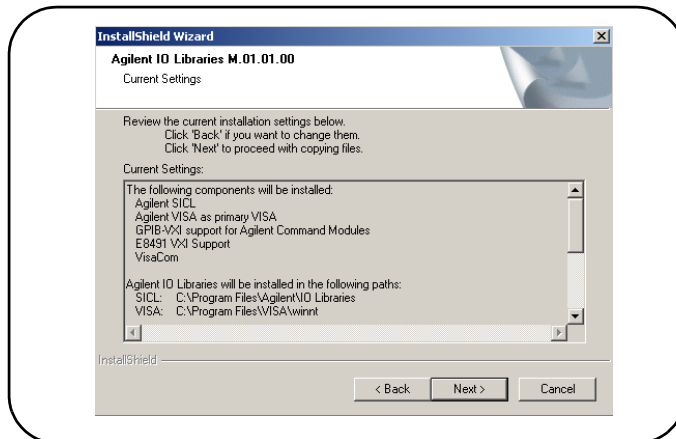

## Step 2: Installing Agilent IO Libraries

- 9 Click **Next>** to accept the settings. Setup will then install the files and display the **Agilent IO Libraries have been successfully installed** screen. For 82357A installation, do NOT check the **Run IO Config** box. (If desired, you can check the **View Readme** box.)

### NOTE

*Even if you do not check the **View Readme** box, after installation is complete, you can view the Readme file by clicking the blue IO icon and clicking **View Documentation | IO Libraries Readme**.*

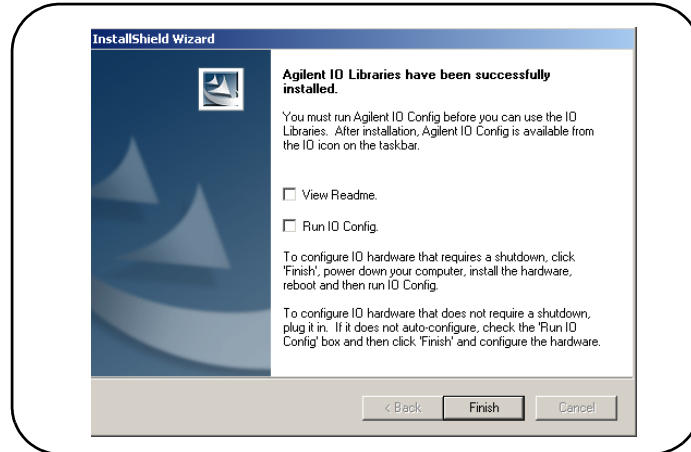

- 10 Click **Finish** to complete the installation of the Agilent IO Libraries. If you checked the **View Readme** box, the Agilent IO Libraries Readme file is also displayed.
- 11 Remove the *Agilent IO Libraries for Instrument Control* CD from the CD-ROM drive.

---

## Step 3: Connecting the 82357A

After the Agilent IO Libraries (Version L.01.00 or later) have been installed, you can connect the 82357A to any USB port on your PC or you can connect the 82357A via standard USB hubs. This step includes:

- 82357A Hardware Description
- Connecting the 82357A to Your PC
- Connecting the 82357A to a USB Hub
- Observing Windows Plug and Play Manager (Windows XP)

### NOTE

*If the Agilent IO Libraries have not been installed on your PC, **STOP**. Install the libraries (see Step 2: Installing the Agilent IO Libraries) and then return to this step.*

### NOTE

*For Windows 98 Second Edition, you may need to install `usbscan.sys`, located on the Windows 98 CD-ROM. See “Check for `usbscan.sys` (Windows 98 SE Only)” in Chapter 3 - Troubleshooting the 82357A for details.*

## 82357A Hardware Description

The Agilent 82357A USB/GPIB Interface Converter (82357A) provides a direct interface connection from the USB port on your PC to GPIB instruments. The 82357A includes an attached USB cable that is USB 1.1 compliant. This cable is shielded and the connector is specified for up to 1,500 insertions.

An 82357A can be directly connected to a single GPIB instrument or can be connected to up to 14 GPIB instruments via GPIB cables. In addition, several 82357As can be connected to your PC via standard USB hubs. The following figure shows main 82357A hardware features.

**Step 3: Connecting the 82357A**

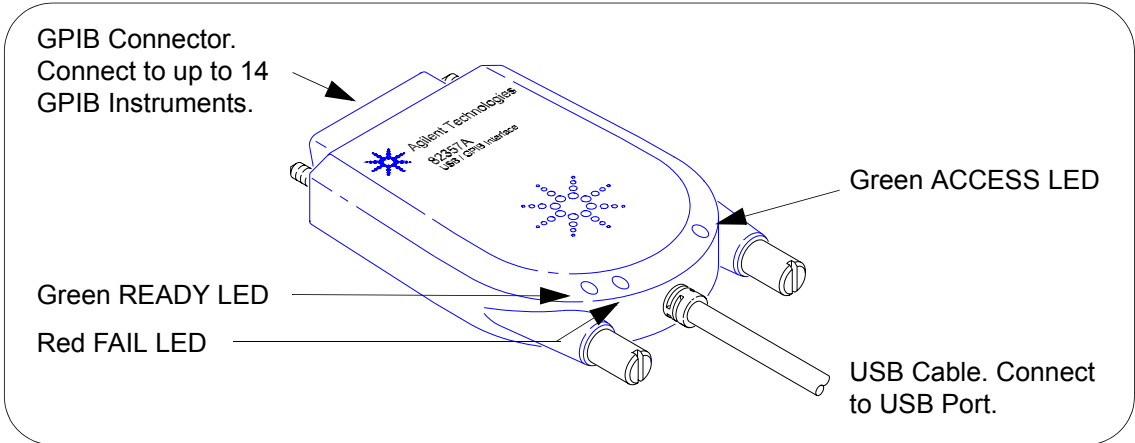

**Connecting the 82357A to Your PC**

This section shows steps to connect the 82357A to a USB port on your PC or to connect to your PC via a USB Hub.

- 1 Connect to a USB Port.** Make sure the PC is ON and plug the 82357A USB cable into any available USB port on your PC. Do not connect the 82357A to GPIB instruments at this time.

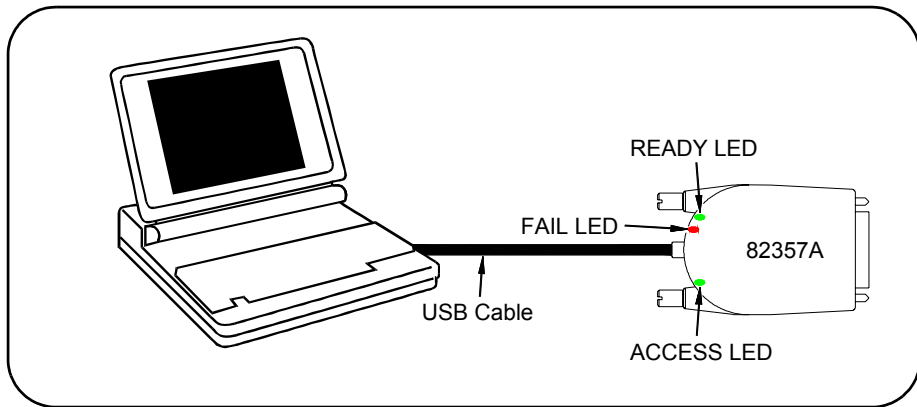



**Step 3: Connecting the 82357A**

- 2 Observe the LEDs.** Observe the LEDs on the 82357A for at least 10 seconds. See *Chapter 2 - Using the 82357A* for a description of the normal LED sequence with an initial installation of an 82357A.
  - a** Initially, only the red FAIL LED should be ON. After a few seconds, all three LEDs should be ON. All three LEDs ON shows the 82357A has been successfully installed, but is not yet configured for use with the Agilent IO Libraries.
  - b** If all three LEDs are *not* ON after 10 seconds and all Windows Plug and Play Manager activity has ceased, **STOP**. See *Chapter 3 - Troubleshooting the 82357A* for diagnostics information.
  - c** If all three LEDs are *still* ON after 10 seconds, go to “Observing Windows Plug and Play Manager Sequence (Windows XP Only)”.

## Connecting the 82357A to a USB Hub

This section shows steps to connect the 82357A to a USB port on your PC via a standard USB hub.

**NOTE**

*Any USB hub used with the 82357A MUST be **self-powered** (must not be bus-powered or powered from the USB bus). Also, be sure to check the applicable USB hub documentation for hub operating parameters, such as power requirements and maximum length of USB cables.*

- 1** Plug the power adapter into the hub and into an electrical outlet. Make sure the hub is operating in self-powered mode. For example, the following figure shows a 4-port self-powered USB hub with two 82357A USB/GPIB Interface Converters connected.
- 2** Make sure your PC is ON. Connect the USB cable of the USB hub to any available USB port on your PC.
- 3** Plug at least one 82357A USB/GPIB Interface Converter into the port(s) on the USB hub. It is not necessary to connect GPIB instruments to any 82357A at this time.

## Installing the 82357A

### Step 3: Connecting the 82357A

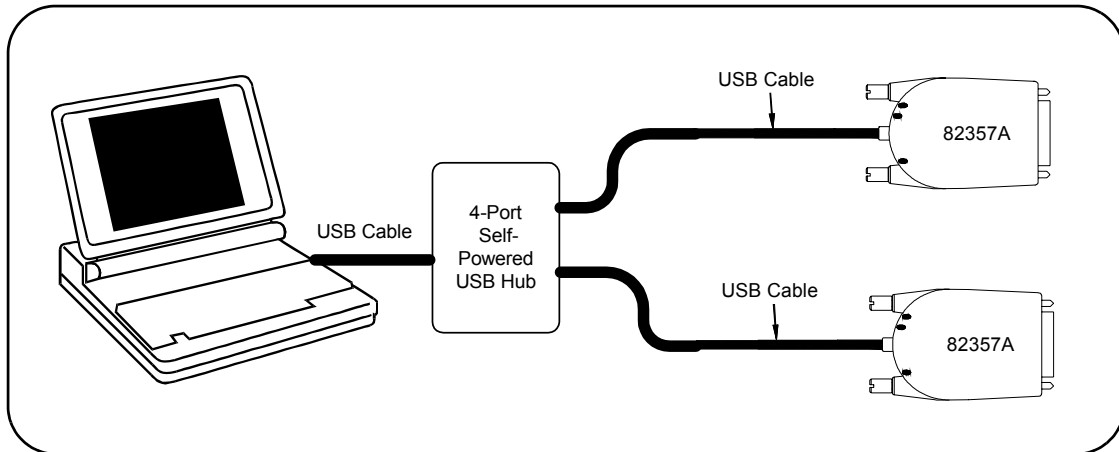

- 4 Observe the LEDs.** Observe the LEDs on the 82357A for at least 10 seconds. See *Chapter 2 - Using the 82357A* for a description of the normal LED sequence with an initial installation of an 82357A.
  - a** Initially, only the red FAIL LED should be ON. After a few seconds, all three LEDs should be ON. All three LEDs ON shows the 82357A has been successfully installed, but is not yet configured for use with the Agilent IO Libraries.
  - b** If all three LEDs are *not* ON after 10 seconds and all Windows Plug and Play Manager activity has ceased, **STOP**. See *Chapter 3 - Troubleshooting the 82357A* for diagnostics information.
  - c** If all three LEDs are *still* ON after 10 seconds, go to “Observing Windows Plug and Play Manager Sequence (Windows XP Only)”.

## Observing Windows Plug and Play Manager Sequence (Windows XP Only)

When an 82357A is first plugged into a USB port, for Windows XP ONLY, a Windows Plug and Play Manager installation sequence may be displayed.

### **NOTE**

*This section shows typical displays for a Windows XP Professional operating system ONLY. Similar displays may appear for Windows 98 SE, Windows 2000, or Windows Me operating systems.*

### Introduction

The following sequence only appears when an 82357A is initially plugged into a USB port. The sequence appears each time an 82357A with a new serial number is installed or when an 82357A is installed in a new USB port.

For example, if an 82357A with Serial Number US12345678 is initially plugged into USB port #1, the sequence may appear. If this 82357A is configured using the sequence, the next time this 82357A is plugged into USB port #1, the sequence will not appear.

However, if another 82357A is plugged into USB port #1 or if the 82357A with Serial Number US12345678 is initially plugged into USB port #2, the sequence may also appear.

### **NOTE**

*The displays in the following sequence assume you have installed the Agilent IO Libraries as shown in Step 2 - Installing Agilent IO Libraries. If you have not installed the libraries, STOP and do Step 2 before continuing.*

**Step 3: Connecting the 82357A**

Typical Windows  
Plug and Play  
Manager Sequence

When an 82357A is initially plugged into a USB port, a **Welcome to the Found New Hardware Wizard** dialog box may appear, as shown in the following figure. If this dialog box appears, select **Install the software automatically (Recommended)** and click **Next>**.

**NOTE**

*Ignore the statement “If your hardware came with an installation CD or floppy disk, insert it now”, as the software has already been installed.*

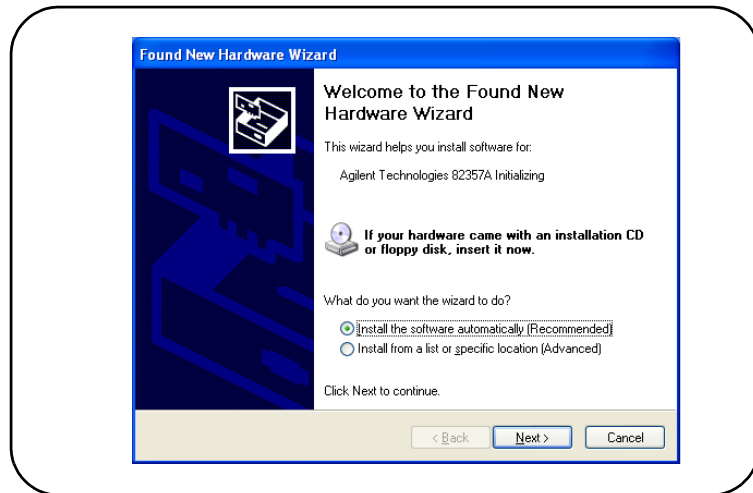

**5** The **Please wait while the wizard searches...** dialog box appears. Wait until the initializing process completes and then click **Next>**.

**6** The **Hardware Installation** dialog box appears.

**NOTE**

*Although the statement “Continuing your installation ... passed Windows Logo testing.” appears, you can safely click the Continue Anyway button.*

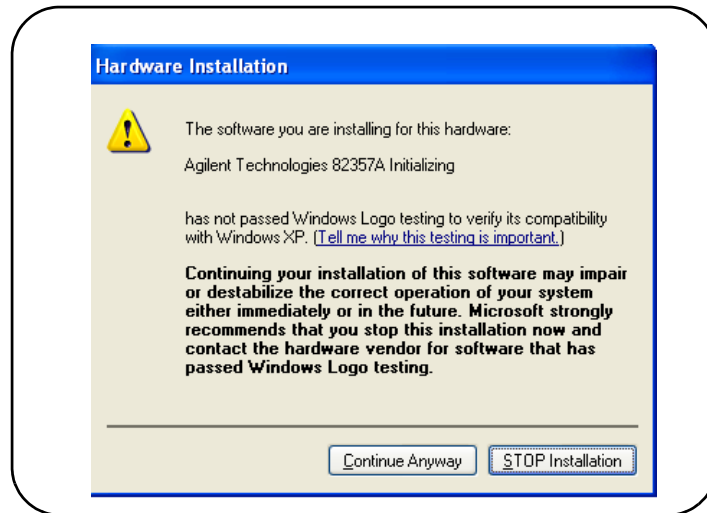

- 7** The **Completing the Found New Hardware Wizard** dialog box appears. Click **Finish** to close the wizard.
- 8** A slightly different version of the **Welcome to the Found New Hardware Wizard** dialog box appears, this time for installing 82357A software. Select **Install the software automatically (Recommended)** and then click **Next>**.

**NOTE**

*Ignore the statement "If your hardware came with an installation CD or floppy disk, insert it now", as the software has already been installed.*

- 9** The **Please wait while the wizard searches...** dialog box appears. Wait until the initializing process completes and click **Next>**.
- 10** A different version of the **Hardware Installation** dialog box appears.

**NOTE**

*Although the statement "Continuing your installation ... passed Windows Logo testing." appears, you can safely click the Continue Anyway button.*

**Step 3: Connecting the 82357A**

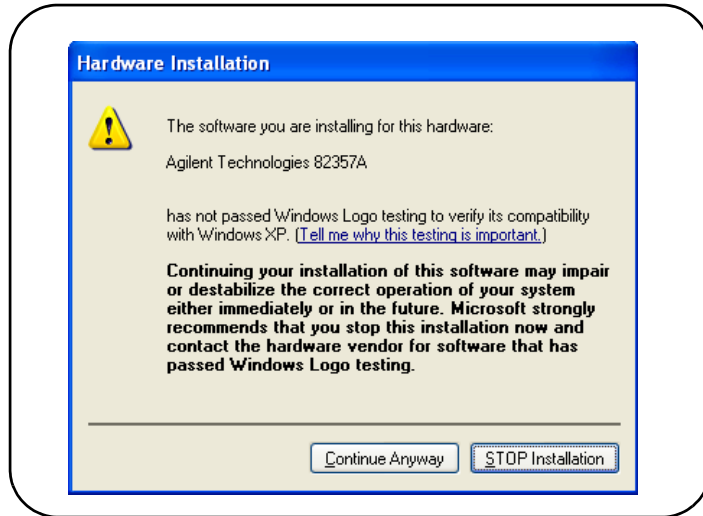

- 11** The **Please wait while the wizard installs the software...** dialog box appears. After the installation is complete, click the **Next>** button to display the **Agilent 82357A USB/GPIB Interface Detected** dialog box. Go to "Step 4: Configuring the 82357A" to continue the installation.

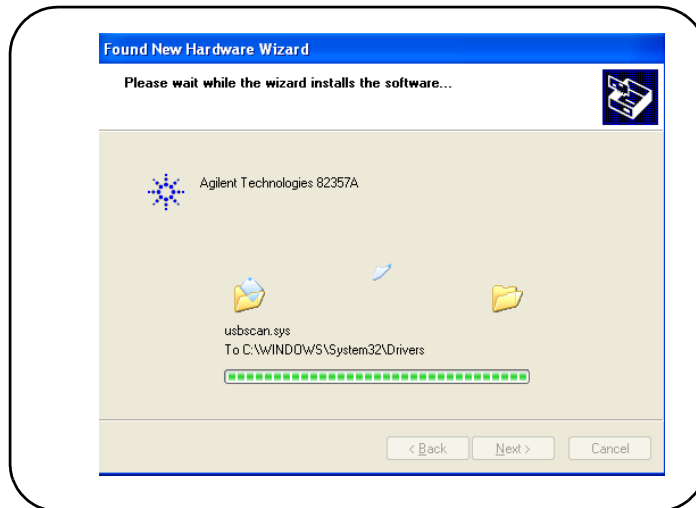

---

## Step 4: Configuring the 82357A

After the 82357A has been installed and the applicable Windows Plug and Play Manager installation sequence has completed, the 82357A must be configured before it can be used with SICL or with Agilent VISA. This step includes:

- Setting 82357A Default Configuration
- Setting 82357A Custom Configuration

### Setting 82357A Default Configuration

This section shows steps to configure an 82357A for default settings by using the **Agilent 82357A USB/GPIB Interface Detected** dialog box. The default configuration should be sufficient for most applications.

- 1 Check LED Status.** Before setting 82357A configuration, verify that all three LEDs on the 82357A are still ON to indicate the 82357A has been successfully installed, but has not yet been configured.
- 2 82357A Interface Detected Box Appears.** After an 82357A has been connected to a USB port and the Windows Plug and Play Manager installation sequence has completed, an **Agilent 82357A USB/GPIB Interface Detected** dialog box should appear.

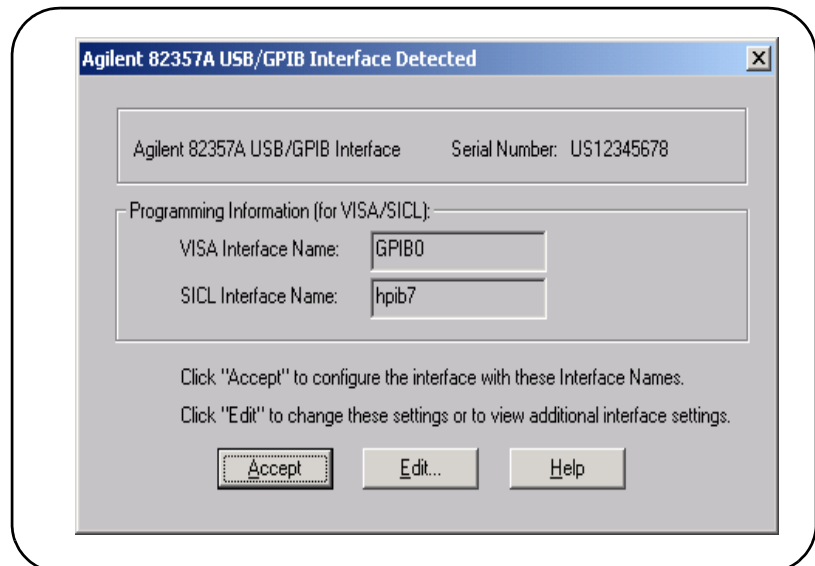

**Step 4: Configuring the 82357A**

- 3** If the **Agilent 82357A USB/GPIB Interface Detected** dialog box does not appear, **STOP**. See *Chapter 3 - Troubleshooting the 82357A* before continuing.

**NOTE**

**Connecting Multiple 82357As.** An **Agilent 82357A USB/GPIB Detected** dialog box should appear each time you plug an 82357A into a USB port . For example, if you plug three 82357As into USB ports, three dialog boxes should appear. Each dialog box will remain until you remove it by clicking **A**cept (or the x box) or **E**dit..

- 4** **Record VISA/SICL Names.** For future programming use, you will need to know the VISA Interface Name and SICL Interface Name as shown on the dialog box. You may want to record these values now.

VISA Interface Name	_____
SICL Interface Name	_____

- 5** **Accept Default Settings.** Click **A**cept (or click the x box) to configure the 82357A with the (default) settings for the VISA Interface Name and the SICL Interface Name shown in the dialog box. If you do not want to accept the default settings, click **E**dit... and see the next section "Setting 82357A Custom Configuration."
- 6** **Only the READY LED Should Remain ON.** After you click **A**cept (or click the x box), the dialog box disappears and only the green READY LED should remain ON to indicate the 82357A has been configured.
- 7** **Configure Multiple 82357A Interface Converters.** If you have more than one 82357A in your system, repeat 1 - 6 for each additional interface converter.

**NOTE**

*At any time after the Agilent IO Libraries are installed, you can reconfigure an 82357A by clicking the blue IO icon and clicking **R**un **I**O **C**onfig.*



## Setting 82357A Custom Configuration

This section shows steps to configure an 82357A for custom configuration settings using the IO Config utility. Typically, you will need to set custom configuration only for specialized applications, such as changing VISA and/or SICL Interface Names or for use in side-by-side operation with National Instruments VISA.

- 1 Check LED Status.** Before setting 82357A configuration, verify that all three LEDs on the 82357A are still ON to indicate the 82357A has been successfully installed, but has not yet been configured.
- 2 82357A Interface Detected Box Appears.** After an 82357A is connected to a USB port and the Windows Plug and Play Manager installation sequence completes, an **Agilent 82357A USB/GPIB Interface Detected** dialog box should appear.
- 3** If this dialog box does not appear, **STOP**. See *Chapter 3 - Troubleshooting the 82357A* before proceeding.

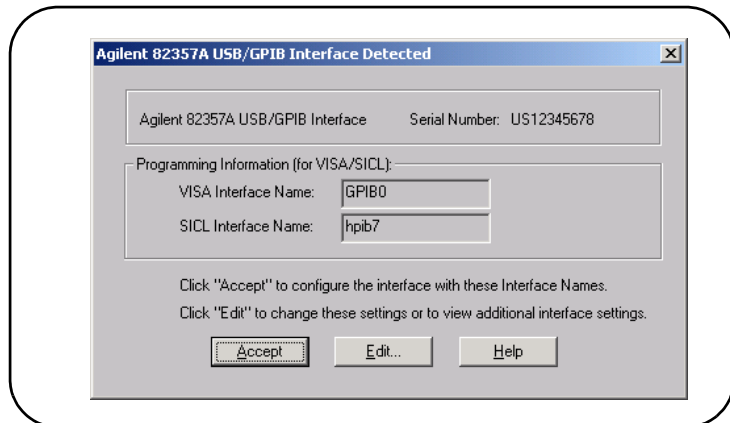

### NOTE

**Connecting Multiple 82357As.** An **Agilent 82357A USB/GPIB Interface Detected** dialog box should appear each time you plug an 82357A into a USB port . For example, if you plug three 82357As into USB ports, three dialog boxes should appear, one for each 82357A. Each dialog box will remain until you remove it by clicking **Accept** (or the **x** box) or **Edit..**

**Step 4: Configuring the 82357A**

- 4 Edit Default Settings.** Clicking **Edit..** allows you to use the IO Config utility to change the settings for the VISA Interface Name and the SICL Interface Name shown in the dialog box, as well as the Logical Unit (LU) number and the Bus Address value.
- 5 All LEDs Should Remain ON.** After you click **Edit..**, the **Agilent 82357A USB/GPIB Interface Detected** dialog box should disappear and all LEDs should remain ON, to indicate the 82357A has been installed but is still not yet configured.
- 6** When the **82357 USB to GPIB Configuration** screen appears, set the **VISA Interface Name**, the **SICL Interface Name**, the **Logical Unit** and **Bus Address** values as required. Then, click the **OK** button.

**NOTE**

*If you click **Cancel**, the original default settings presented in the **Agilent 82357A USB/GPIB Interface Detected** dialog box will be used.*

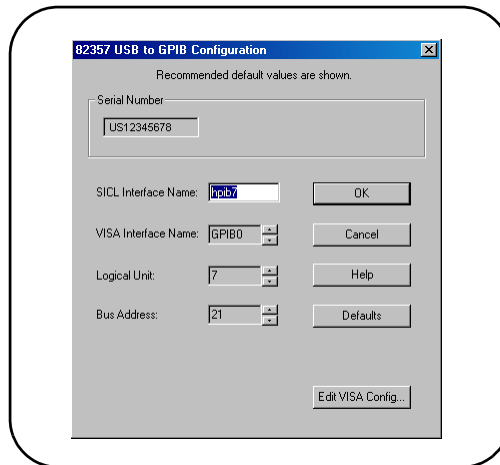

- 7 Only the Green READY LED Should Remain ON.** After you click **OK**, the dialog box disappears and only the green READY LED should remain ON to indicate the 82357A has been configured.

**Step 4: Configuring the 82357A**

- 8 Record VISA/SICL Names.** For future programming use, you will need to know the VISA Interface Name and SICL Interface Name as shown on the dialog box. After you finish editing the 82357A configurations, you may want to record these values.

VISA Interface Name	_____
SICL Interface Name	_____

- 9 Configure Multiple 82357A Interface Converters.** If you have more than one 82357A in your system, repeat 1 - 8 for each additional interface converter.

**NOTE**

*At any time after the Agilent IO Libraries are installed, you can configure an 82357A by clicking the blue IO icon and clicking **Run IO Config**.*

---

## Step 5: Connecting GPIB Instruments

After the 82357A has been installed and configured, the next step is to connect GPIB instruments to the 82357A. This step includes:

- Connecting a Single GPIB instrument
- Connecting Multiple GPIB Instruments

### CAUTION

*To avoid damage to the connectors, only finger-tighten the connectors.*

### Connecting a Single GPIB Instrument

The following figure shows connection from a single GPIB instrument to the GPIB port on an 82357A. When you have made the connection for your system, go to “Step 6: Programming via the 82357A”. You may want to record the primary GPIB address of the attached instrument for future programming use.

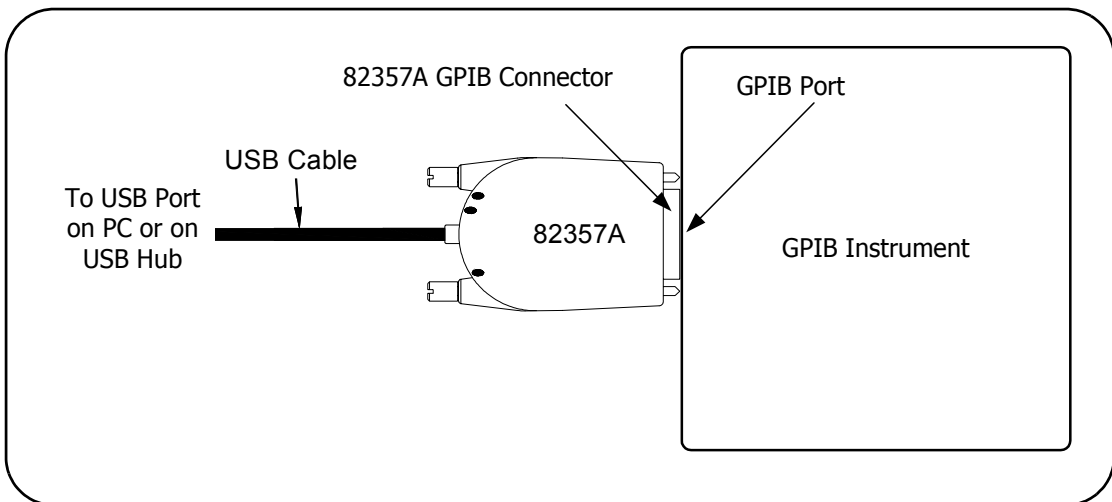

## Connecting Multiple GPIB Instruments

The following figure shows a typical way to connect three GPIB instruments to an 82357A. When you have made the connections for your system, go to “Step 6: Programming via the 82357A”. You may want to record the primary GPIB address of each attached instrument for future programming use

### NOTE

*Although the figure shows 82357A connection to GPIB Instrument 1, the connection can be to any GPIB instrument in the system. Be sure to first connect the GPIB cable to the GPIB instrument and then “piggy-back” the 82357A GPIB connector to the GPIB cable.*

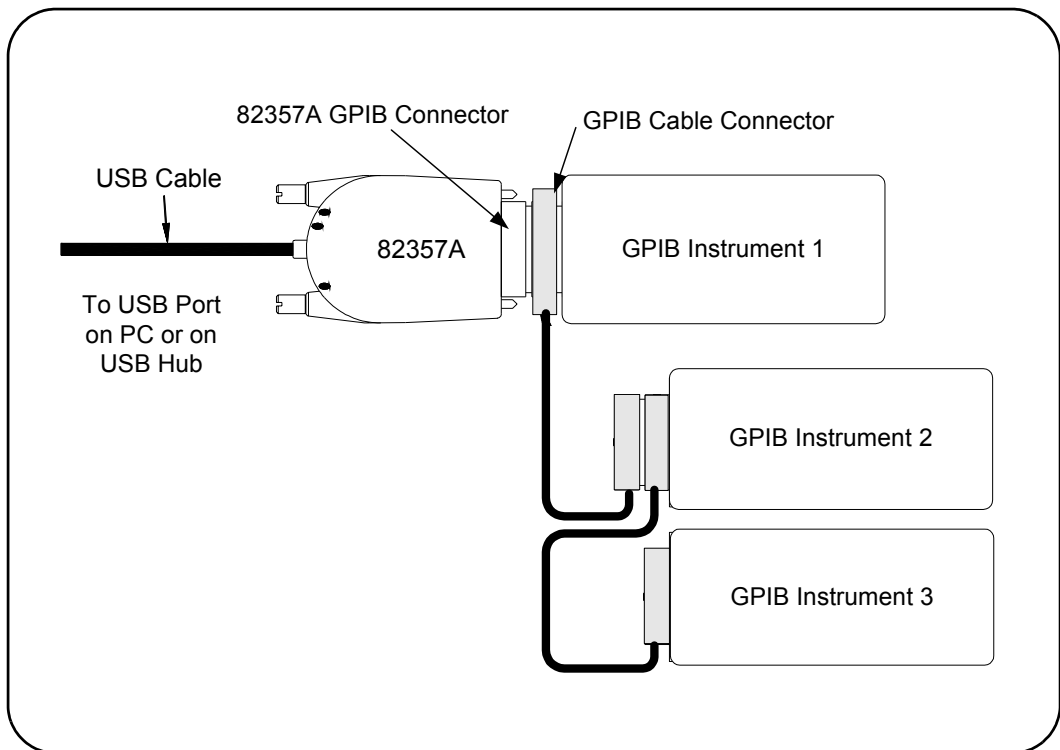

## Step 6: Programming via the 82357A

After the 82357A has been configured and you have connected your GPIB instruments to the 82357A, the next step is to establish communication between your PC and the instruments using VISA Assistant. After communication has been established, you can begin programming the instruments using VISA or SICL. This section includes:

- Establishing Instrument Communication
- Programming GPIB Instruments

### Establishing Instrument Communication

When the Agilent IO Libraries were installed on your PC, an IO utility called **VISA Assistant** was also installed. You can use VISA Assistant to verify communication between your PC and connected GPIB instruments. To use VISA Assistant for IEEE-488.2 or SCPI instruments:

- 1 Click the blue IO icon on the Windows taskbar (on the lower right-hand corner of the screen).
- 2 Click **Run VISA Assistant** to display the VISA Assistant main screen. For information on VISA Assistant, click **Help**.

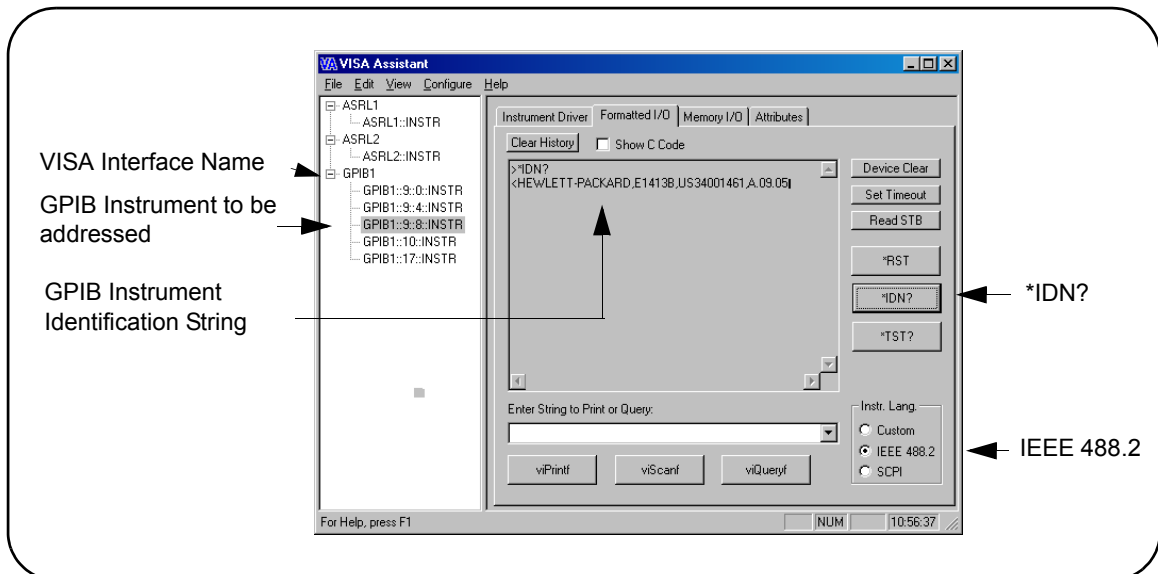

- 3** Maximize the VISA Assistant main screen.
- 4** Highlight the GPIB instrument to be addressed.
- 5** Select the **Formatted I/O** Tab.
- 6** Select the **IEEE 488.2** button.
- 7** Click the **\*IDN?** button.
- 8** The GPIB Instrument String should appear.
- 9** Repeat Steps 4 - 8 for the next GPIB instrument.
- 10** When communication has been established with each GPIB instrument, you can begin to program the instruments using VISA or SICL. See the next section “Programming GPIB Instruments” for an introduction.

## Programming GPIB Instruments

This section provides an introduction to programming GPIB instruments via the 82357A USB/GPIB Interface Converter using the Agilent VISA and SICL IO Libraries. You can program in various languages/applications, including Visual Basic, Visual C++, Intuilink, Agilent VEE, and National Instruments LabView.

See the applicable User's Guide, such as the *Visual Basic User's Guide*, for programming guidelines. You can also find additional programming examples using VXI Plug&Play drivers in the instrument User's Guide. After the 82357A is successfully installed and configured, the Interface Converter should act as a transparent interface for programming GPIB instruments.

For information on programming using Agilent VISA, see the *Agilent VISA User's Guide*. Also, see *Appendix B - Using the Agilent IO Libraries* for information on the Agilent IO Libraries.

## Step 6: Programming via the 82357A

Accessing VISA and SICL Manuals You can access .pdf copies of the *Agilent VISA User's Guide* and the *Agilent SICL User's Guide for Windows* from the blue IO icon on the Windows taskbar. Adobe Acrobat Reader is required to view these manuals.

To access the *Agilent VISA User's Guide*, click the IO icon and then click **View Documentation | VISA Users Guide**. To access the *Agilent SICL User's Guide for Windows*, click the IO icon and then click **View Documentation | SICL Users Guide**.

Introduction to IO Interface Configuration An **IO interface** consists of a hardware interface and a software interface. The purpose of the IO Config utility is to associate a unique software interface name with a hardware interface.

The Agilent IO Libraries use an **Interface Name** or **Logical Unit Number** to identify an interface. This information is passed in the parameter string of the **viOpen** function call in a VISA program or in the **iopen** function call in a SICL program.

IO Config assigns an Interface Name and Logical Unit (LU) Number to the interface hardware, as well as other necessary configuration values for an interface when the interface is configured. Typically, the LU Number is automatically assigned and you can ignore its setting. The LU Number is used internally as a unique identifier. When the IO interface is configured, you can use Agilent VISA or SICL to program assigned instruments.

Example: IO Interface Configuration For example, the GPIB interface system in the following figure consists of a Windows PC with an 82357A USB/GPIB Interface Converter connected between a USB port and three GPIB instruments with GPIB primary addresses of 3, 4, and 5, respectively. The instruments are connected via GPIB cables.

For this system, the IO Config utility has been used to assign a VISA name of "GPIB1" and a SICL name of "hpb7". With these names assigned to the interfaces, the VISA/SICL addressing is as shown in the figure.

Since unique names have been assigned by IO Config, you can use the VISA **viOpen** command to open the IO paths to the GPIB instruments as shown in the figure. Or, you can use the SICL **iopen** command to open the IO paths.



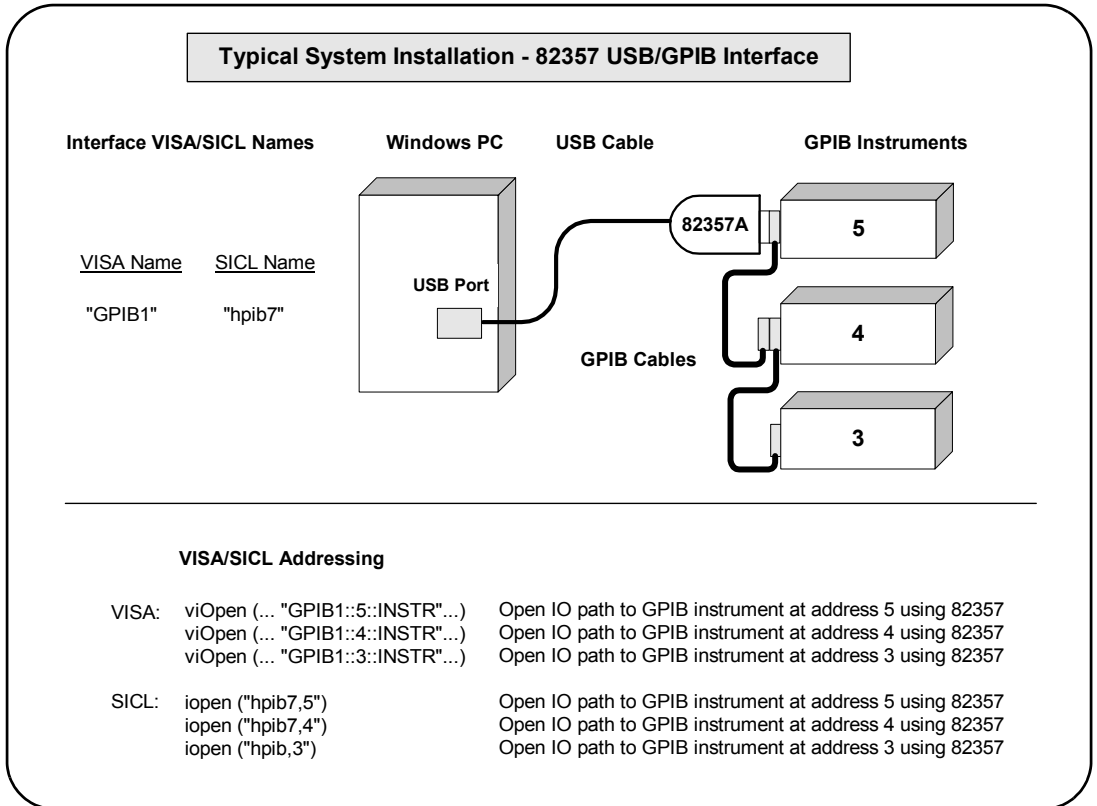

Installing the 82357A

**Step 6: Programming via the 82357A**

***Notes:***

---

**Using the 82357A**

---

---

## Using the 82357A

This chapter describes normal operating states for the 82357A and gives guidelines to use the 82357A including:

- Modes of Operation
- Setting Configuration Parameters

## Modes of Operation

This section describes normal operational modes for the 82357A, including:

- Initial 82357A Operating States
- Introduction to 82357A Operating Modes
- Single 82357A Operation
- Multiple 82357A Operation
- SRQ Operation

### Initial 82357A Operating States

The following figure shows the sequence of initial operating states when the 82357A is first connected to a USB port on a PC or on a USB hub.

	State	Description	LED States		
			READY (Green)	FAIL (Red)	ACCESS (Green)
1	82357A Connected, No Power	82357A is connected to a USB port on the PC or on a USB hub, but no power is applied to the 82357A.	○	○	○
2	82357A Connected, Power Applied	Power is applied to the 82357A from the USB port, but startup firmware not yet downloaded.	○	●	○
3	82357A Installed but not Configured	Host computer has downloaded startup firmware to the 82357A. The 82357A has been installed but not yet configured.	●	●	●
4	Normal Operation, Idle State	82357A has been configured for operation with the Agilent IO Libraries.	●	○	○
5	Normal Operation, GPIB Transfers	The ACCESS LED is ON for any GPIB transfers.	●	○	◐

○ LED OFF   ● LED ON   ◐ Intermittent

## Introduction to 82357A Operating Modes

The 82357A has two modes of operation. When only one 82357A is connected to a USB port within a system, we define the operation as the **single mode of operation**. When two or more 82357As are connected at the same time to USB ports within a system, we define the operation as the **multiple mode of operation**.

### NOTE

*All SICL/VISA applications are notified when their 82357A has been removed from the system by returning **VI\_ERR\_NOINFC** (for VISA) or **I\_ERR\_NCIC** (for SICL).*

### Single Mode Features

For the single mode of operation, the operating parameters (VISA Interface Name, SICL Interface Name, Logical Unit Number, and Bus Address) are set when the 82357A is first installed and configured.

If this 82357A is unplugged and replugged or if the 82357A is replaced with a *different* 82357A, the original configuration parameters are automatically assigned to the newly attached 82357A. Thus, you can exchange 82357As at any time without reconfiguring the interface. This allows exchanging 82357As among users, as long as only one 82357A is attached at any one time.

### Multiple Mode Features

In contrast, when two or more 82357As are connected to the system at the same time, each 82357A must have its own specific set of operating parameters and each 82357A Serial Number is “bound” to its operating parameters. In multiple mode of operation, if you add a new 82357A or if you unplug an 82357A and plug in a new 82357A, the newly installed 82357A will be assigned a new (unique) set of operating parameters.

### NOTE

*Each time you attach a new 82357A, an **Agilent 82357A USB/GPIB Interface Detected** dialog box will be displayed.*

## Single 82357A Operation

When an 82357A is first installed and configured, a default VISA Interface Name, SICL Interface Name, Logical Unit (LU) number and Bus Address are automatically assigned to the Serial Number associated with this specific 82357A.

For example, assume an 82357A with Serial Number US12345678. When this 82357A is first installed, typical values as shown are automatically assigned to this Serial Number.

- VISA Interface Name: GPIB0
- SICL Interface Name: hpib7
- Logical Unit: 7
- Bus Address: 21

For *single mode of operation*, when the existing 82357A is removed and a new 82357A is installed, the new 82357A assumes all configuration attributes of the previously configured 82357A (same VISA Interface Name, SICL Interface Name, LU and Bus Address). Thus, any SICL/VISA applications using that VISA/SICL configuration will continue to run using the new 82357A.

### NOTE

*You can change the parameter values of the 82357A as required. See “Changing Configuration Parameters” for details.*

The first time an 82357A is attached to a system (assuming the Agilent IO Libraries are installed), the software recognizes that an 82357A is attached and starts the IO Config utility. IO Config then displays an **Agilent 82357A USB/GPIB Interface Detected** dialog box that allows you to accept or edit the current settings.

After you accept or edit the dialog box, the VISA and SICL interface names may be viewed at a later time in the **Configured Interface** box in the IO Config main screen. (To view this screen, click the blue IO icon and then click **Run IO Config**.)

Then, if you disconnect this 82357A and plug in another 82357A (with a different Serial Number) or if you re-plug the same 82357A, the new 82357A will assume the same VISA Interface Name, SICL Interface Name, LU, and Bus Address as the original 82357A.

## Multiple 82357A Operation

When two or more 82357As are attached to a system at the same time, we define the mode as the **multiple mode of operation**. In multiple mode of operation, each 82357A is "bound" to its related IO Configuration for that Serial Number. This is a different mode of operation than for single mode of operation in that the configuration is not reused if you replace an 82357A with another 82357A.

As with single mode of operation, the first time an 82357A is attached to a system (assuming the Agilent IO Libraries are installed), the software recognizes that an 82357A is attached and starts the IO Config utility. IO Config then displays an **Agilent 82357A USB/GPIB Interface Detected** dialog box that allows you to accept or edit the current settings.

After you accept or edit the dialog box, the VISA and SICL interface names are displayed in the **Configured Interface** box in the IO Config main screen. (To view this screen, click the blue IO icon and then click **Run IO Config**.)

Then, if you plug in another 82357A (with a different Serial Number), the new 82357A will automatically be assigned a unique VISA Interface Name, SICL Interface Name, LU, and Bus Address.

### NOTE

*You can change the parameter values of the 82357A as required. See "Changing Configuration Parameters" for details.*

*You can also convert from multiple mode of operation to single mode of operation. See "Changing Modes of Operation" for details.*

## SRQ Operation

If your VISA/SICL application uses SRQ callbacks (**viEventHandler()** in VISA or **ionsrq()** in SICL) and your callback does not service the SRQ in a timely manner, your SRQ callback function may be called multiple times.

To avoid this possible situation, design your SRQ callback functions to handle being called when an SRQ is no longer asserted on the GPIB bus.



---

## Setting Configuration Parameters

This section gives guidelines to change or set various configuration parameters for the 82357A, including:

- Changing Configuration Parameters
- Changing Modes of Operation
- Setting Timeout Floor Value
- Setting High-Performance Operation

## Changing Configuration Parameters

To change the VISA or SICL Interface Name or the LU or Bus Address value, or if you want to check the values, click the **Edit..** button from the **Agilent 82357A USB/GPIB Interface Detected** dialog box to display the **82357 USB to GPIB Configuration** dialog box. Choose the settings you want and then click **OK**. Clicking **Cancel** will cause the configuration set in the preceding dialog box to be used. .

### NOTE

*Although you can change the Logical Unit (LU) and Bus Address values for an 82357A, this is generally not necessary and may cause running applications to fail or to stop running.*

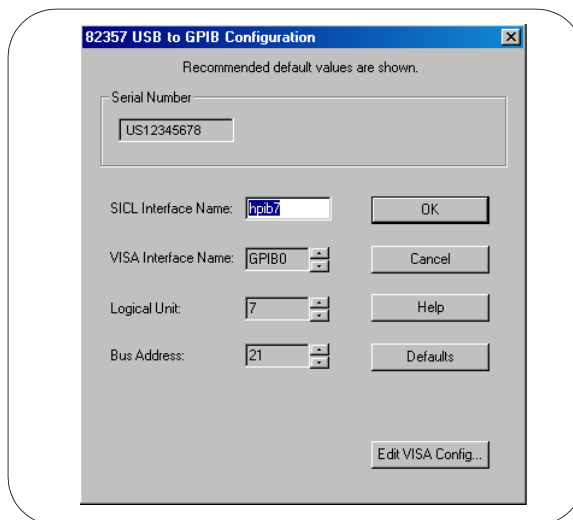

## Changing Modes of Operation

If your system has multiple 82357As configured (multiple mode of operation), the **only** way to change from multiple mode of operation back to the single mode of operation is:

- 1 Unplug all 82357As from the system.
- 2 Run IO Config (click the blue IO icon and click **Run IO Config**).
- 3 Delete all 82357A configurations from the **Configured Interface** box in the IO Config utility main screen (or delete all except one configuration).
- 4 Reattach and reconfigure a single 82357A.

## Setting Timeout Floor Values

The 82357A has a default timeout "floor" value that is an internal requirement to ensure reliable USB communication. The 82357A will not allow timeouts LESS than the floor value. (By default, VISA/SICL timeouts are set to an infinite time.)

To programatically determine the timeout floor, you can set the timeout to a very small value, such as 1 msec, and then query for the actual timeout floor value. VISA and SICL examples follow.

Example: Query  
Timeout Floor  
(VISA)

```
tval = 1; // Try to set timeout to 1 msec
err = viSetAttribute(id, VI_ATTR_TMO_VALUE, tval_in);
...
err = viGetAttribute(id, VI_ATTR_TMO_VALUE, &tval_out);
...
printf("Set timeout to [%d], actual timeout that resulted [%d]\n",
      tval_in, tval_out );
```

Example: Query  
TimeOut Floor  
(SICL)

```
tval = 1; // Try to set timeout to 1 msec
err = itimeout(id, tval_in);
...
err = igettimeout(id, &tval_out);
...
printf("Set timeout to [%d], actual timeout that resulted [%d]\n",
      tval_in, tval_out );
```

## Setting 82357A High-Performance Operation

**NOTE**

*Changing the T1 delay as described in this section is an advanced feature and also requires attention to cable lengths and other system features.*

**Introduction**

The GPIB transfer rate for 82357A writes using large (>1000 bytes) buffer size is affected by the Data Available (T1) delay time. (The transfer rates are not noticeably affected when the buffer size is <1000 bytes). The default delay time used by the 82357A is 800 nsec.

The maximum transfer rate for T1 = 350 nsec is about 900 KBytes/sec as compared to about 650 KBytes/sec for the 82357A default value of 800 nsec. Changing the T1 delay affects ONLY the *write* performance of the 82357A.

**Setting T1 Value With VISA**

To set the T1 value with VISA, use the **VI\_AGATTR\_GPIB\_T1\_DELAY** attribute. The **VI\_AGATTR\_GPIB\_T1\_DELAY** value is the time of the T1 delay in nanoseconds, and should be no less than **VI\_AG\_GPIB\_T1DELAY\_MIN** or no greater than **VI\_AG\_GPIB\_T1DELAY\_MAX**. This value is defined in Agilent's 'visa.h' header file. To use this value, you must **#define AGVISA\_ATTRIBUTES** before the **#include "visa.h"** in your C or C++ source file.

The 82357A supports T1 delays from 350 nsec to *<max\_value>* in steps of 40 nsec. You can find out the actual value by calling **viGetAttribute()**.

Attribute	Access Priv.	Data Type	Range (nsec)	Used By
<b>VI_AGATTR_GPIB_T1_DELAY</b>	RW Global	ViInt32	<b>VI_AG_GPIB_T1DELAY_MIN</b> to <b>VI_AG_GPIB_T1DELAY_MAX</b>	GPIB INTFC resources

**Setting T1 Value With SICL**

To set the T1 value with SICL, use the **igpibsett1delay()** command and modify the GPIB environment. For further information, you may want to see the Hewlett-Packard document "Tutorial Description of the Hewlett-Packard Interface Bus". See Section 2.12, Optimizing Performance.

***Notes:***

---

---

**Troubleshooting the 82357A**

---

---

## Troubleshooting the 82357A

This chapter provides troubleshooting guidelines and service/support information for the Agilent 82357A USB/GPIB Interface Converter.

The chapter contents are:

- Troubleshooting Flowchart
- Hardware Checks
- Software Installation Checks
- Software Configuration Checks
- Service and Support Information

---

## Troubleshooting Flowchart

The figure on the next page shows a suggested sequence of steps to diagnose and troubleshoot 82357A problems, based on the LED states. You can use the LED states to help diagnose and troubleshoot the 82357A whenever the LED states do not match expected normal states. See *Chapter 2 - Using the 82357A* for the normal LED sequence when the 82357A is initially connected to a USB port.

### Observe the LED States

To begin troubleshooting, determine the LED states after at least 10 seconds have elapsed since the 82357A was connected to a USB port and all Windows Plug and Play Manager activity has ceased. Then:

- If all LEDs are OFF, start with “Hardware Checks”
- If the red FAIL LED is ON, start with “Software Installation Checks”
- If all LEDs are ON, start with “Software Configuration Checks”

After taking the steps in the check sequence, use the boxes at the bottom of the chart to determine the next step. For example, if doing a Hardware Check results in only the red FAIL LED remaining ON, go to “Software Installation Checks”, etc.

#### **NOTE**

*You do not have to do all the steps or do the steps in the order shown. If any action results in a change in LED states, go to the applicable check sequence to continue troubleshooting.*

## Troubleshooting the 82357A Troubleshooting Flowchart

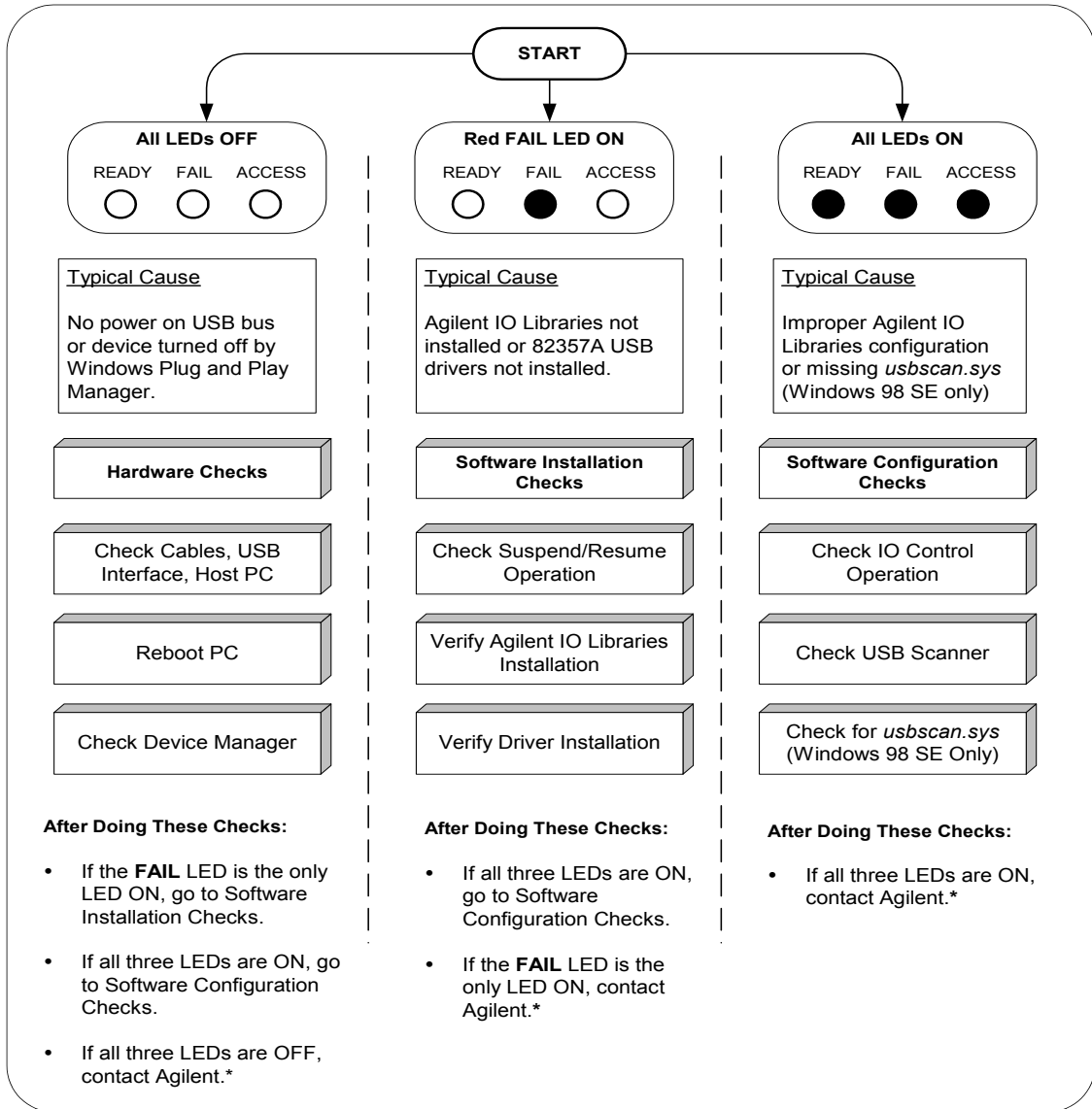

\*For telephone and web assistance, see "Contacting Agilent" on page 58.



---

## Hardware Checks

If all LEDs are still OFF 10 or more seconds after plugging the 82357A USB cable into a USB port and all Windows Plug and Play Manager activity has ceased, start your troubleshooting sequence by performing hardware checks. If any action taken results in a change in the LED status, go to “Software Installation Checks” or to “Software Configuration Checks”.

### Check USB Cables, USB Interface, Host PC

Begin the hardware checks by checking connections between the 82357A and PC (plus USB hubs, if used).

- 1 Check USB Cable Connections.** Check the 82357A USB cable for a good connection to the USB port on the PC or on the USB hub. If you are using a USB hub, verify that the hub is connected to the PC.
- 2 Unplug/replug the 82357 USB cable.** If this does not change the LED status, try plugging the 82357A into another USB port.
- 3 Check PC USB Port.** Verify that the PC USB port is functional and powered (such as checking by using another USB device).
- 4 Check PC State.** Verify that host computer is not in a Suspended power management state.
- 5 Check USB Hub.** Try disconnecting the 82357A from the hub and connecting it directly to a USB port on the PC. Some USB hubs are vulnerable to static shock.
- 6 Check USB Cables for Damage.** Check the USB cable for cuts/crashes. Since the end connectors are somewhat fragile, check for bent/misaligned/crushed connectors.

### Reboot the PC

If Steps 1, 2, 3,4, 5, or 6 do not change the LED status, reboot the PC.

## Hardware Checks

### Check Device Manager

You can use the Windows Device Manager to reinstall the 82357A, as required. For example, with Windows 2000, go to **Control Panel** by selecting **Start | Settings | Control Panel**.

Then, select **System | Hardware | Device Manager**. From **Device Manager**, select **82357** and then **Properties**. Tab to **Driver** and click **Reinstall Driver**. This will allow the Windows Plug and Play Manager to begin searching for a driver for the 82357A. Since **Device Manager** may have disabled the 82357A USB device, click **Enable** to restart the 82357A.

#### NOTE

*If you are using a USB scanner, scanner conflicts are possible. See "Check USB Scanner" in the Software Configuration Checks section.*

---

## Software Installation Checks

When only the red FAIL LED is still ON after 10 seconds, the 82357A has been detected by the host computer, but has not yet been configured for use with the Agilent IO Libraries. Possible causes for this is that the appropriate version of the Agilent IO Libraries has not been installed on your PC or the 82357A USB drivers have not been installed.

### Check Suspend/Resume Operation

Some Windows operating systems support Power Management which can suspend the PC while the 82357A is in operation. After a Suspend/Resume cycle, the 82357A may not properly resume operation. In this case, you may need to unplug/replug the USB cable to restore 82357A operation. If this does not correct the problem, go to “Verify Agilent IO Libraries Installation”.

#### NOTE

*If your 82357A applications must not be pre-empted by a PC Suspend event, we recommend you disable Power Management on your PC by using the **Control Panel | Power Options** dialog.*

### Verify Agilent IO Libraries Installation

When only the red LED is ON after 10 seconds and all Windows Plug and Play Manager activity has ceased, start your troubleshooting sequence by verifying IO Libraries installation. If any action taken results in a change in the LED status, go to “Software Configuration Checks” or to “Hardware Checks”.

- 1 Check Agilent IO Libraries Version.** If a version of the Agilent IO Libraries has been installed, a blue **IO** icon is normally displayed on the Windows taskbar (on the lower right-hand side of the screen).

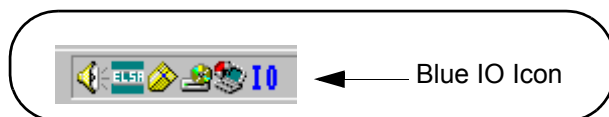

## Software Installation Checks

- a** If the IO icon is displayed, click the icon and click **About Agilent IO Libraries Control** to display the version. The version must be L.01.00 or greater.
  - b** If the IO icon is not displayed, a version may still be installed. To check this, click **Start | Programs** and look for the **Agilent IO Libraries** program group.
  - c** If this group is displayed, click **Agilent IO Libraries | IO Control** to display the IO icon. Then, click the icon and click **About Agilent IO Libraries Control** to display the installed version (must be L.01.00 or greater).
  - d** If neither the IO icon nor the Agilent IO Libraries program group is displayed, no Agilent IO Libraries are installed. In this case, or if the installed version is not L.01.00 or greater, you must install the newer version (see Step 2).
- 2 Install Agilent IO Libraries (as Required).** If Version L.01.00 or greater of the Agilent IO Libraries is not installed on your PC, use this step. Otherwise, skip to “Verify 82357A USB Driver Files Installation”.
- a** Remove the 82357A USB cable from the USB port.
  - b** Insert the *Agilent IO Libraries for Instrument Control* CD (Version L.01.00 or later) in your CD-ROM drive and follow the instructions in *Chapter 1 - Installing the 82357A* to install the libraries.
  - c** Re-attach the 82357A USB cable to the USB port and check the LEDs for at least 10 seconds.
    - If only the red FAIL LED remains ON, go to “Verify 82357A USB Driver Installation”.
    - If all three LEDs remain ON, go to “Software Configuration Checks”.

## Verify 82357A USB Driver Installation

After installing the Agilent IO Libraries, check for installed driver files.

- 1 Check for Driver Files.** This table lists the USB driver files in their default directories.

Windows 2000	
Program Files	<i>C:/Program Files/Agilent/IO Libraries/drivers/ag357i32.dll</i>
Driver Files	<i>C:/Winnt/system32/drivers/agt82357.sys</i>
.inf Files	<i>C:/Winnt/inf/agt357.inf</i>
Windows 98 (SE)/Me/XP	
Program Files	<i>C:/Program Files/Agilent/IO Libraries/drivers/ag357i3l.dll</i>
Driver Files	<i>C:/Windows/system32/drivers/agt82357.sys</i>
.inf Files	<i>C:/Windows/inf/agt357.inf</i>

- 2 Uninstall the Agilent IO Libraries.** If the driver files cannot be found, uninstall the Agilent IO Libraries by inserting the *Agilent IO Libraries for Instrument Control* CD and clicking **Remove** and **Next>**. Then, follow the instructions to remove the libraries.
- 3 Reinstall the Agilent IO libraries.** Remove and reinsert the CD into the CD-ROM. Follow the instructions in *Chapter 1 - Installing the 82357A* to install the libraries.
  - If only the FAIL LED remains ON, go to “Hardware Checks”.
  - If all three LEDs turn ON, go to “Software Configuration Checks”.
  - If the red FAIL LED still does not turn OFF, contact Agilent.

---

## Software Configuration Checks

If all three LEDs remain ON for more than 10 seconds after the 82357A is connected to a USB port, the 82357A has been installed but is not yet configured for use with the Agilent IO Libraries.

When all three LEDs are ON after 10 seconds, start your troubleshooting sequence by checking IO Control operation. If any action taken results in a change in the LED status, go to “Software Installation Checks” or “Hardware Checks”, as applicable.

### NOTE

*If you are using the 82357A with Windows 98 (SE), before beginning these checks verify that your operating system is Windows 98 (SE), not Windows 98, First (“Gold”) Edition. The 82357A will not operate correctly for a Windows 98, First Edition operating system.*

## Checking IO Control Operation

When the Agilent IO Libraries were installed, an IO Control was created. When the IO Control is active, it is displayed as a blue IO icon on the Windows taskbar. By default, the IO Control is always active after the libraries are installed and the blue IO icon is displayed. However, if the IO Control is deactivated, SICL/VISA applications that are running with the 82357A will malfunction. Some symptoms that may occur when IO Control is not active include:

- An **Agilent 82357A USB/GPIB Interface Detected** dialog box does not appear when an 82357A is first connected to a USB port.
- SICL/VISA applications using the 82357A are unable to open sessions.
- The Windows Task Manager shows that iproc82357.exe is not running or is non-responsive.

If any of these symptoms occur, use the following troubleshooting sequence:

- 1 **Unplug/Replug the 82357A.** If unplugging and replugging the 82357A causes the **Agilent 82357A USB/GPIB Interface Detected** dialog box to appear, the problem is solved. If not, go to Step 2.

- 2 Shutdown and Restart IO Control.** Take these steps to shut down and then restart the IO Control. Taking these actions should result in all attached and configured 82357As to be initialized and to display only the green Ready LED
  - a** If the blue IO icon is displayed, click the icon and then click **Exit**. A dialog box explaining the consequences of removing the IO Control appears. Click **OK** to shut down the IO Control.
  - b** If the blue IO icon is not displayed, either the icon display has been turned off or the IO Control (and associated *iprocsvr.exe* and *iprocsvr.exe*) are not active. In this case, select **Start | Programs | Agilent IO Libraries** and click **IO Control** to re-start the IO Control and display the blue IO icon.

**NOTE**

*Rebooting your PC should ALWAYS restart the IO Control and iprocsvr.exe and iproc82357.exe.*

## **Check USB Scanner**

In general, USB scanners do not cause problems with the 82357A. However, if you do have problems with 82357A operation and have a scanner installed on your system that uses a USB port, unplug the scanner and then plug the 82357A into the port.

If the 82357A will configure without your scanner attached to your system, the scanner was locking out the 82357A from using the USB bus. In this case, contact your scanner's manufacturer to request software or firmware updates for the scanner.

## Check for *usbscan.sys* (Windows 98 SE Only)

The 82357A relies on a Microsoft driver called *usbscan.sys* that ships with Windows 98/Me/2000/XP. However, for Windows 98 SE, this file and its parent file, *driver20.cab*, may not be installed on your PC. Typically, the *usbscan.sys* file is located under the system root directory at `\WINDOWS\SYSTEM32\DRIVERS\`.

### NOTE

*usbscan.sys* parent *.cab* file name is different for each Windows release. The "driver20.cab" file name only applies to Windows 98 SE. The *usbscan.sys* install problem is NOT expected on Windows Me/2000/XP systems.

### Windows 98 SE Symptoms

If the *usbscan.sys* driver and the Microsoft *.cab* file (typically named "driver20.cab" on Windows 98 systems) are not resident on your Windows 98 SE system, after you install the Agilent IO Libraries and connect an 82357A to a USB port, a Windows Plug and Play Manager dialog box appears that queries you for the location of *usbscan.sys*; *driver20.cab*. If this dialog box appears:

- **If you have a Windows 98 SE CD:** Insert the CD and browse to `x:\Win98`. The install process will resume and the 82357A will begin operation.
- **If you do not have a Windows 98 SE CD:** Click **Cancel** on the dialog box. Then, use one of the following methods to obtain the CD and follow the step above.
  - Locate the original Windows 98 SE Installation CD
  - Contact your System Administrator for the CD
  - Contact Microsoft for a replacement CD



**Assigning *usbscan* Driver to the 82357A** If, when you initially plugged an 82357A into a USB port, a Windows Plug and Play Manager dialog box appeared that requested the location of *usbscan.sys* and you were forced to click **Cancel** from this dialog box, see the following information in this section. Otherwise, skip this section.

After an initial attachment of an 82357A to a system without *usbscan.sys* installed, future unplugs/replugs of an 82357A will result in the system (silently) assigning the wrong driver and not querying the user for the *usbscan.sys* driver location. This action leaves the 82357A inoperative, with all 3 LEDs ON (assuming the Agilent IO Libraries are installed).

To properly associate the *usbscan.sys* driver with an 82357A, you can either update the driver using the Windows Device Manager utility or uninstall/reinstall the Agilent IO libraries (with the 82357A unattached) and then attach the 82357A and provide the Windows 98 SE media location to the Plug and Play Manager.

#### **Uninstall/Reinstall the Agilent IO Libraries**

With this method, the 82357A install software (found in the Agilent IO Libraries installer) cleans the Windows Registry of any memory of an 82357A being on the system, forcing the Plug and Play Manager to query again for the location of *usbscan.sys*. This method has the side effect of removing any Agilent IO Library IO Configurations established previously.

Disconnect all 82357As from the USB ports. Then, uninstall and reinstall the Agilent IO libraries (version L.01.00 or greater). Attach the 82357A and provide the Windows 98 SE media location to the Windows Plug and Play Manager.

#### **Update the Driver using Windows Device Manager**

With this method, you tell Windows that a new driver is to be assigned to the 82357A. This method requires you to locate where the Device Manager has mistakenly located the 82357A device.

- 1** Start Windows Device Manager and select the 82357A device, usually presented in Device Manager as an "Other" type device. Then, select Properties for that device and then select the Driver tab in the resulting dialog.
- 2** Click the "**Update driver...**" button and provide the Windows 98 SE CD when prompted. This forces the Windows Plug and Play Manager to reassess the drivers needed for that device, allowing you to provide the *usbscan.sys* source media location.

## **Service/Support Information**

This section provides service and support information for the 82357A and lists numbers and a Web site you can use to contact Agilent about the 82357A.

### **82357A Service Information**

There are no user-servicable parts for the Agilent 82357A USB/GPIB Interface Converter. If you suspect a hardware failure for the 82357A, contact Agilent for instructions to return the unit. See the following section “Contacting Agilent” for telephone numbers/web site address.

### **Contacting Agilent**

- You can reach Agilent Technologies at these telephone numbers:

Americas Call Center:	1-800-829-4444
Canada Call Center:	1-877-894-4414
European Call Center:	+31-20-547-9900
Japan Call Center:	+81-426-56-7832

- For other countries, contact your country’s Agilent support organization. A list of contact information for other countries is available on the Agilent web site:

<http://www.agilent.com/find/assist>

---

**82357A User's Guide Information**

---

---

## 82357A User's Guide Information

This chapter provides general information for the *82357A User's Guide*, including:

- Guide Contents
- Guide General Information

## Guide Contents

This *Agilent 82357A USB/GPIB Interface Converter User's Guide* shows how to install and configure the Agilent 82357A USB/GPIB Interface Converter for PCs with Windows 98 (SE), Windows Me, Windows 2000, or Windows XP Professional operating systems. This table summarizes the contents of this guide.

Chapter	Description
<i>Chapter 1 - Installing the 82357A</i>	Shows a suggested six-step process to install the 82357A and the Agilent IO Libraries, to connect the 82357A to your PC, to configure the 82357A, and to program GPIB instruments via the 82357A
<i>Chapter 2 - Using the 82357A</i>	Describes 82357A modes of operation and shows how to set 82357A configuration parameters.
<i>Chapter 3 - Troubleshooting the 82357A</i>	Gives guidelines to troubleshoot the 82357A, including hardware and software checks, and provides service and support information for the 82357A.
<i>Chapter 4 - User Guide Information</i>	Provides guide contents and general information for this guide.
<i>Appendix A - 82357A Specifications</i>	Provides technical specifications and supplementary information for the 82357A.
<i>Appendix B - Using the Agilent IO Libraries</i>	Describes the Agilent IO Libraries and shows how to install runtime and custom IO libraries.

## **Guide General Information**

General Information for this guide follows, including:

- Notice
- U.S. Government Restricted Rights
- Warranty Information
- Trademark Information
- Printing History
- Copyright Information
- Declaration of Conformity

### **Notice**

The information contained in this document is subject to change without notice.

Agilent Technologies shall not be liable for any errors contained in this document. *Agilent Technologies makes no warranties of any kind with regard to this document, whether express or implied. Agilent Technologies specifically disclaims the implied warranties of merchantability and fitness for a particular purpose.* Agilent Technologies shall not be liable for any direct, indirect, special, incidental, or consequential damages, whether based on contract, tort, or any other legal theory, in connection with the furnishing of this document or the use of the information in this document.

### **U.S. Government Restricted Rights**

The Software and Documentation have been developed entirely at private expense. They are delivered and licensed as "commercial computer software" as defined in DFARS 252.227- 7013 (Oct 1988), DFARS 252.211-7015 (May 1991) or DFARS 252.227-7014 (Jun 1995), as a "commercial item" as defined in FAR 2.101(a), or as "Restricted computer software" as defined in FAR 52.227-19 (Jun 1987) (or any equivalent agency regulation or contract clause), whichever is applicable. You have only those rights provided for such Software and Documentation by the applicable FAR or DFARS clause or the Agilent standard software agreement for the product involved.

## **Warranty Information**

A copy of the specific warranty terms applicable to your Agilent Technologies product and replacement parts can be obtained from Agilent Technologies, Inc.

## **Trademark Information**

Windows ® 98, Windows ® Me, Windows™ NT 4.0, Windows ® 2000 and Windows XP™ Professional are U.S. registered trademarks of Microsoft Corporation. All other brand and product names are trademarks or registered trademarks of their respective companies.

## **Printing History**

Edition 1 - January 2002

Edition 2 - March 2003

Edition 3 - May 2004

## **Copyright Information**

*Agilent Technologies 82357A USB/GPIB Interface Converter  
User's Guide*



Copyright © 2002-2004 Agilent Technologies, Inc.

All rights reserved.

## **Declaration of Conformity**

See the next page for the Declaration of Conformity for the 82357A USB/GPIB Interface Converter.

82357A User's Guide Information  
Guide General Information

 <b>Agilent Technologies</b>	<b>DECLARATION OF CONFORMITY</b> According to ISO/IEC Guide 22 and CEN/CENELEC EN 45014	
---	--	---

**Manufacturer's Name:** Agilent Technologies, Incorporated  
**Manufacturer's Address:** 815 – 14<sup>th</sup> St. SW  
Loveland, CO 80537  
USA

**Declares under sole responsibility that the product as originally delivered**

**Product Name:** USB/GPIB Interface Converter  
**Model Number:** 82357A  
**Product Options:** This declaration covers all options of the above product(s)

**complies with the essential requirements of the following applicable European Directives, and carries the CE marking accordingly:**

EMC Directive (89/336/EEC, amended by 93/68/EEC)  
Low Voltage Directive (73/23/EEC, amended by 93/68/EEC)

**and conforms with the following product standards:**

EMC	Standard	Limit
	IEC 61326-1:1997+A1:1998 / EN 61326-1:1997+A1:1998	
	CISPR 11:1990 / EN 55011:1991	Group 1 Class A
	IEC 61000-4-2:1995+A1:1998 / EN 61000-4-2:1995	4 kV CD, 8 kV AD
	IEC 61000-4-3:1995 / EN 61000-4-3:1995	3 V/m, 80-1000 MHz
	IEC 61000-4-4:1995 / EN 61000-4-4:1995	0.5 kV signal lines
	IEC 61000-4-6:1996 / EN 61000-4-6:1996	3 V, 0.15-80 MHz 1 cycle, 100%
	Canada: ICES-001:1998	
	Australia/New Zealand: AS/NZS 2064.1	

The product was tested in a typical configuration with Agilent Technologies test systems.

**Safety** IEC 61010-1:2001 / EN 61010-1:2001  
Canada: CSA C22.2 No. 1010.1:1992  
UL 61010B-1: 2003

**Supplementary Information:**

**This DoC applies to above-listed products placed on the EU market after:**

20 April 2004

Date



**Ray Corson**

Product Regulations Program Manager

For further information, please contact your local Agilent Technologies sales office, agent or distributor, or Agilent Technologies Deutschland GmbH, Herrenberger Straße 130, D 71034 Böblingen, Germany.



---

**A**

---

**82357A Specifications**

---

---

## **82357A Specifications**

This appendix lists 82357A USB/GPIB Interface Converter Technical Specifications and Supplementary Information.

## Technical Specifications

<b>General Requirements</b>	
Minimum System Requirements	Windows 98 Second Edition /Me/2000/XP Professional, Pentium® -200, 32 MB RAM, 50 MB free disk space, USB port (OS may require more resources)
Supported Standards	USB 1.1*, IEEE-488.1 and IEEE-488.2 compatible, SICL and VISA 2.2
Supported Applications (with IntuiLink)	Microsoft Excel 97 and 2000; Microsoft Word 97 and 2000. Check the web for latest supported applications.
Supported Software Development Applications	Visual Basic 6.0, Visual C++ 6.0, Visual Studio 6.0, Agilent VEE 6.0 or greater, BASIC for Windows, LabVIEW 6.0 or greater
<b>General Characteristics</b>	
Power	USB bus powered device, +5V, 500 mA (max), 200 mA (typ)
Connectors	Standard 24-pin IEEE-488, Standard USB A
USB Hubs	Self-powered hubs (Optional)
Dimensions	105 mm (L) x 64 mm (W) x 30 mm (H) (includes connectors)
Weight	215 grams
Cable	2.5 Meters, shielded, 1500 insertions
Indicators	READY, ACCESS, FAIL
Warranty	1 year
<b>Environmental Specifications</b>	
Operating Environment	0°C to 55°C
Storage Environment	-40°C to +75°C
Humidity	up to 65% (0°C to 40°C)
Storage Humidity	up to 65% ( 0°C to 55°C)
<b>Ordering Information</b>	
Interface	82357A USB/GPIB Interface Converter
Options	Opt 0B1 - Add Manual Set
Accessories	None

\* USB 2.0 interfaces support the USB 1.1 standard.

---

## Supplementary Information

This section provides supplementary information on the 82357A performance, including supported GPIB modes. The 82357A is defined as a **controller** as it can be (and is required to be) the system controller.

### GPIB Modes of Operation Supported

The 82357A supports standard GPIB modes of operation, except for:

- Parallel Poll (PPOLL)
- Passing of Active Controller
- Non-System Controller mode, which prevents using SICL Commander sessions or VISA Servant sessions

### IEEE-488.1 and IEEE-488.2 Compliance

The 82357A is in full compliance with IEEE 488.1 and IEEE-488.2 specifications. The 82357A fully supports IEEE-488.1 subsets AH1, C1, C2, C3, C4, C27, DC0, DT0, LE3, PP0, RL0, SH1, SR0, and TE7.

### SRQ Response Time

SRQ response time is slower than with the 82350 PCI GPIB interface as an artifact of the USB implementation. In addition, sharing the USB bus with other devices may impact GPIB performance.

### Default T1 Delay

The default T1 delay for the 82357A is 800 nsec. See “Setting 82357A High-Performance Operation” in *Chapter 2 - Using the 82357A* for details.

### Maximum 82357A System Configuration

Up to four 82357As on a system have been successfully tested.

---

**B**

---

**Using the Agilent IO Libraries**

---

---

## Using the Agilent IO Libraries

This appendix describes the Agilent IO Libraries and gives guidelines to install runtime and custom versions of the libraries, including:

- Agilent IO Libraries Description
- Using the Agilent IO Libraries CD
- Installing Runtime Agilent IO Libraries
- Installing Custom Agilent IO Libraries

### NOTE

*The Agilent IO Libraries Installation and Configuration Guide contains a complete description of the Agilent IO Libraries.*

*Before you install the libraries, you can copy an electronic version of this guide from the Agilent IO Libraries for Instrument Control CD that shipped with your 82357A. See “Using the Agilent IO Libraries CD” in this appendix for details.*

*After the libraries are installed, you can access the guide by clicking the blue **IO** icon on the Windows taskbar and then clicking **View Documentation | IO Libraries Installation Guide**.*

## Agilent IO Libraries Description

The Agilent IO Libraries software consists of Agilent VISA, SICL, and IO utilities plus an IO Libraries Control. The software is contained on the *Agilent IO Libraries for Instrument Control* CD that shipped with your 82357A. The Agilent IO Libraries are required to communicate from the host computer via the 82357A to installed GPIB instruments.

You can make calls into VISA or SICL from your own applications (such as Microsoft Visual C++, Visual Basic, etc.) or you can use applications that make these calls for you (such as *IntuiLink*, *VISA Assistant*, etc.).

## Agilent IO Libraries Components

The following table shows the parts of the libraries that apply to the 82357A. For information on each part, click the blue IO icon and then click **View Documentation**. Then, click the item(s) shown in the table.

IO Libraries		
Agilent VISA	<i>Agilent Virtual Instrument Software Architecture (VISA)</i> is an IO library that can be used to develop IO applications and instrument drivers that comply with <i>VXIplug&amp;play</i> standards.	<i>VISA Users Guide</i>
SICL	<i>Standard Instrument Control Library (SICL)</i> is an IO library developed by Agilent that is portable across many IO interfaces and systems.	<i>SICL Users Guide</i>
IO Utilities		
IO Config	The IO Config utility is used by the Agilent IO Libraries to configure the 82357A. The 82357A must be configured with IO Config before the interface can be used with the Agilent IO Libraries.	<i>Run IO Config   Help</i>
VISA Assistant	VISA Assistant is an application program that can be used to control and communicate with GPIB instruments via the 82357A interface.	<i>Run VISA Assistant   Help</i>
VISA COM I/O	VISA COM I/O is based on the VISA I/O architecture. VISA COM is multivendor and has a Global Resource Manager (GRM) that can find and use Vendor-Specific Resource Managers (SRMs) to find and create sessions to all system resources.	<i>VISACOM Help</i>

## Agilent IO Libraries Control

During installation, an Agilent IO Libraries Control icon is created. This icon is located on the Windows taskbar and is shown as a blue **IO** symbol.



A typical display follows when **View Documentation** is selected.

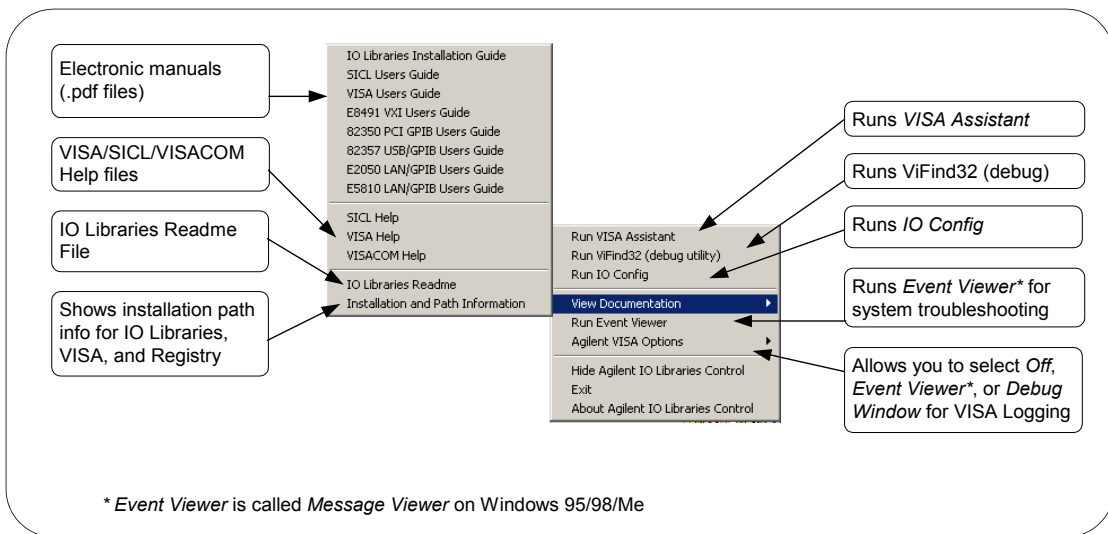

This table summarizes the items that can be displayed by clicking the **IO** control.

Item	Description
<b>Run VISA Assistant</b>	Allows you to run the <i>VISA Assistant</i> utility. <i>VISA Assistant</i> is an application program that uses the <i>VISA I/O Library</i> to communicate with and control instruments via LAN, USB, VXI, GPIB, or Serial Interfaces.
<b>Run ViFind32 (debug utility)</b>	Opens the <i>ViFind32</i> debug utility you can use to list <i>VISA</i> resources. <i>ViFind32</i> is a debug utility that lists (in a console window) all <i>VISA</i> resources found.



Item	Description
<b>Run IO Config</b>	Allows you to run the <i>IO Config</i> utility. IO Config is used by the Agilent IO Libraries to configure instrument I/O hardware interfaces. An interface must be configured with IO Config before the interface can be used with the IO Libraries.
<b>View Documentation</b>	Allows you to display online (.pdf) documentation, VISA, SICL and VISACOM Help files, the Agilent IO Libraries Readme file, and Installation and Path Information.
<b>Run Event Viewer/ Run Message Viewer</b>	For Windows 2000 and XP, displays the Windows Event Viewer. For Windows 98 (SE) and Windows Me, displays Run Message Viewer and opens the IO Libraries debug message viewer.
<b>Agilent VISA Options</b>	Allows you to select VISA Logging or Default VISA LockWait. VISA Logging allows you to select Off (default), Event Viewer or Debug Window. Default VISA LockWait allows you to select False (default) or True.
<b>Hide Agilent IO Libraries Control</b>	Clicking this causes the blue IO icon to be hidden, but does not shut down the IO Control utility. To restore this icon, select <b>Start   Programs   Agilent IO Libraries</b> and click <b>IO Control</b> .
<b>Exit</b>	Clicking this shuts down the IO Control utility and causes the blue IO icon to disappear. However, be careful about doing this, as the IO Control utility <b>MUST</b> be running to use an 82357A. To restore this icon and the IO Control utility, select <b>Start   Programs   Agilent IO Libraries</b> and click <b>IO Control</b> .
<b>About Agilent IO Libraries Control</b>	Displays the currently installed version of the Agilent IO Libraries.

After the Agilent IO Libraries have been installed, if the IO Libraries Control icon is not visible, you can display the icon by clicking **Start | Programs | Agilent IO Libraries | IO Control**.

**NOTE**

*Adobe Acrobat Reader is required to view manuals available from the Agilent IO Libraries Control. (Online Help files and the Readme file do not require Acrobat Reader.) If Adobe Acrobat Reader is not present, no error message appears, but manuals will not be displayed.*

## Program Groups Created

During installation, the Agilent IO Libraries program group is created. After the libraries are installed, to access this group click **Start | Programs | Agilent IO Libraries** to display the following icons.

Two installed utilities are useful for the 82357A: IO Config and VISA Assistant. Clicking **View Documentation | Installation and Path Information** displays the IO Libraries, VISA, and Registry installation paths. This is primarily useful for troubleshooting installation problems.

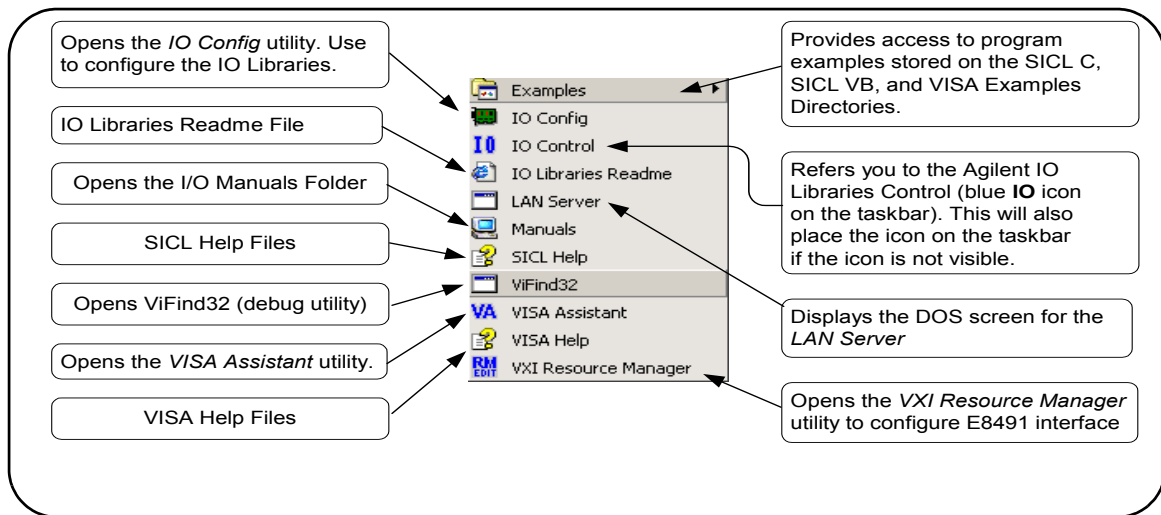

---

## Using the Agilent IO Libraries CD

The *Agilent IO Libraries for Instrument Control* CD that shipped with your 82357A includes all the information that is installed on your PC when you install the Agilent IO Libraries.

### Introduction

However, if you have not yet installed the libraries, but need a description of the libraries or are interested in troubleshooting information, you can access this information by copying applicable files to your PC. This section shows how to copy the *Agilent IO Libraries Installation and Configuration Guide for Windows*

### Copying the Installation Guide File

The *Agilent IO Libraries Installation and Configuration Guide for Windows* contains a full description of the Agilent IO Libraries and shows detailed installation and configuration steps. A .pdf version of the manual is on the *Agilent IO Library for Instrument Control* CD that shipped with your 82357A. (Adobe Acrobat® Reader is required to view the .pdf file.)

As desired, you can copy the file to a directory of your choice so you can refer to the guide as you do the installation procedure. If you do not want to copy the file now, the guide will be available as part of the IO Libraries after installation is complete. To copy the installation guide file to your directory:

- 1** Turn the PC ON, insert the *Agilent IO Libraries for Instrument Control* CD into the CD-ROM drive, and wait a few seconds for the application to run.
- 2** The installer should automatically start when the CD is inserted. If not, select **Start | Run** and browse to and select **Setup.exe** on your CD-ROM. Click **Open** to run the application.

Using the Agilent IO Libraries  
**Using the Agilent IO Libraries CD**

- 3 The InstallShield® Wizard appears to begin the Agilent IO Libraries installation. **Immediately** click the **Cancel** button to stop the installation.

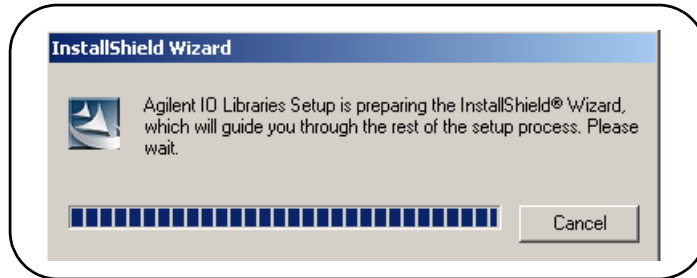

- 4 Open your Windows Explorer and navigate to *<drive>* | Manuals | install.pdf.
- 5 Copy install.pdf to a directory on your PC.
- 6 Remove the *Agilent IO Libraries for Instrument Control* CD from the CD-ROM.

---

## Installing Runtime Agilent IO Libraries

This section shows steps to perform a Runtime Installation of the Agilent IO Libraries. To perform a Full Installation, see *Chapter 1 - Installing the Agilent IO Libraries*. To perform a Custom Installation of the libraries, see “Installing Custom IO Libraries” in this chapter.

- 1 Turn the PC ON and, as required, install application software such as C/C++, VEE, etc. on your PC.
- 2 Insert the *Agilent IO Libraries for Instrument Control* CD into the CD-ROM drive and wait a few seconds for the application to run. The installer should automatically start when the CD is inserted. If not, select **Start | Run** and type **<drive>:setup.exe**, where **drive** is your CD-ROM drive.
- 3 The InstallShield® Wizard appears to begin the Agilent IO Libraries installation.

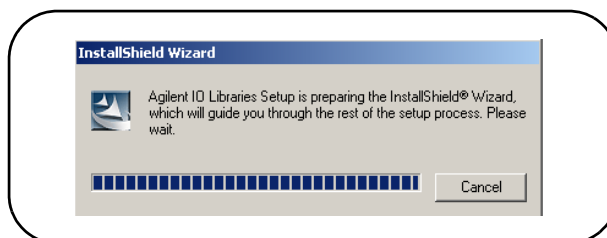

- 4 After a few seconds, the **Title Screen** appears.

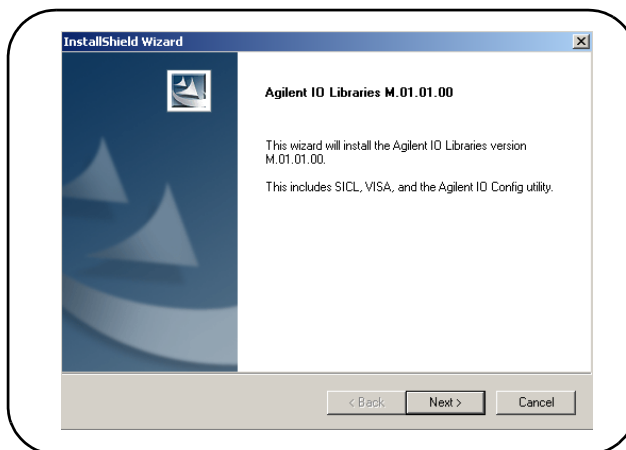

## Using the Agilent IO Libraries

### Installing Runtime Agilent IO Libraries

- From the **Title Screen**, click **Next>** to go to the **License Agreement** screen and then click **Yes** to accept the license terms and to display the **Readme Information** screen.

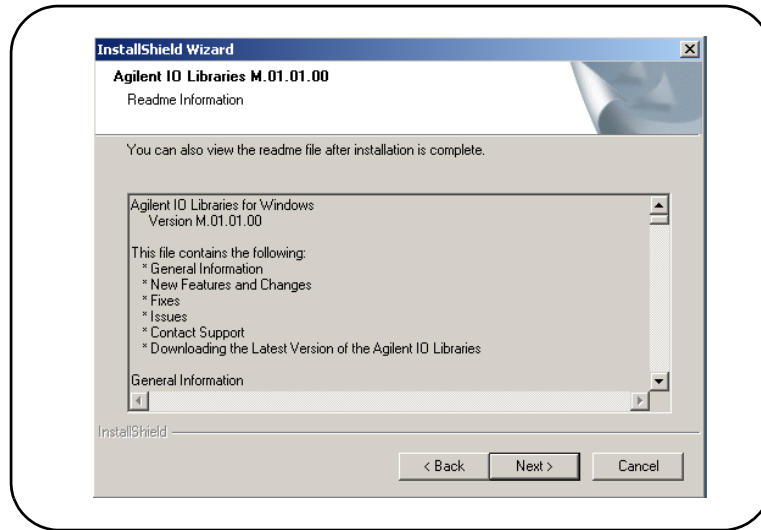

- Scroll through the **Readme Information** screen to display the latest Agilent IO Libraries information.
  - We highly recommend you read the **Readme Information** screen for the latest installation information before proceeding further with the installation.
  - If you do not want to read the **Readme Information** screen at this time, after the Agilent IO Libraries are installed you can view the Readme information by clicking the blue IO icon on the Windows taskbar and then clicking **View Documentation | IO Libraries Readme**
- When finished with the **Readme Information** screen, click **Next>** to display the **Select the Installation Option** screen. Click the **Runtime Installation** box and then click **Next>**.

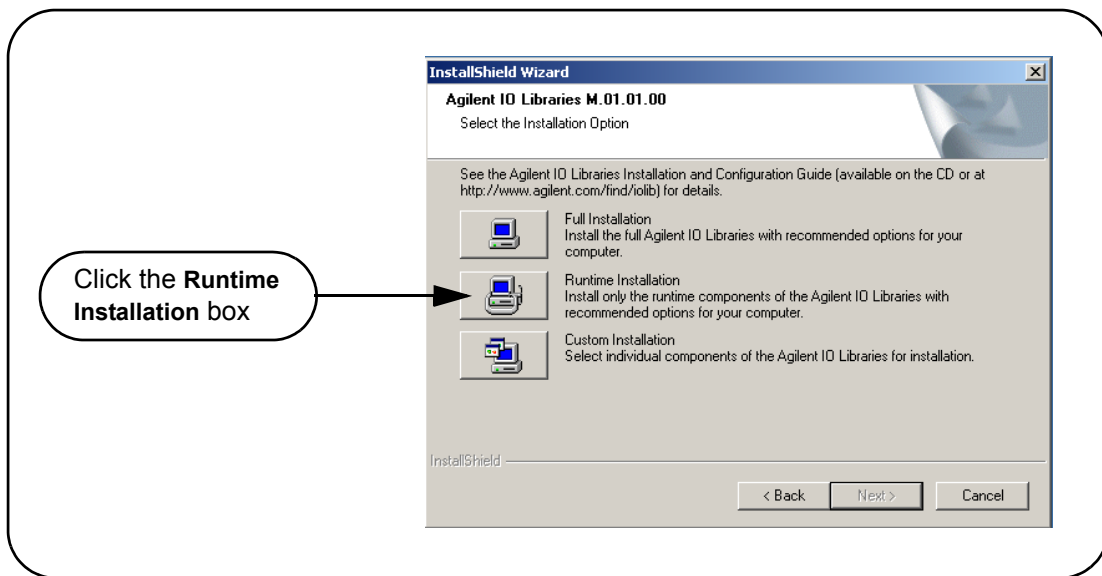

- 8 The **Current Settings** dialog box appears. This box shows the (default) paths in which SICL and VISA will be installed and the components that will be installed.

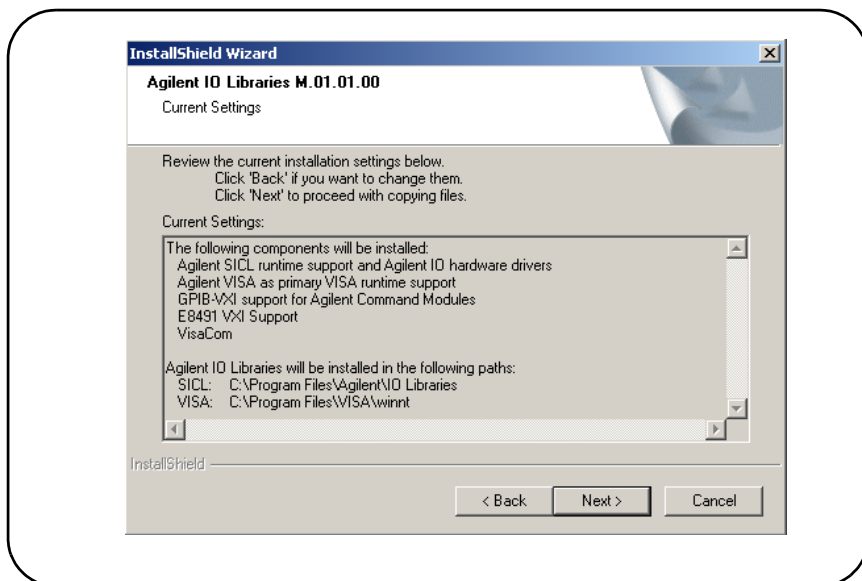

## Using the Agilent IO Libraries

### Installing Runtime Agilent IO Libraries

- a To Accept the Settings.** Click **Next>**. Setup will then install the files and display the **Agilent IO Libraries have been successfully installed** screen (see Step 9).
  - b To Change the Settings.** Click **<Back** to re-display the **Select the Installation Option** screen (see Step 7). From this screen, click the **Custom Installation** box and then click **Next>** to proceed with a custom installation. See “Installing Custom Agilent IO Libraries” for installation details.
- 9** The **Agilent IO Libraries have been successfully installed** screen appears. For 82357A installation, the 82357A is preconfigured and it is not necessary to check the **Run IO Config** box. (If desired, you can check the **View Readme** box.)

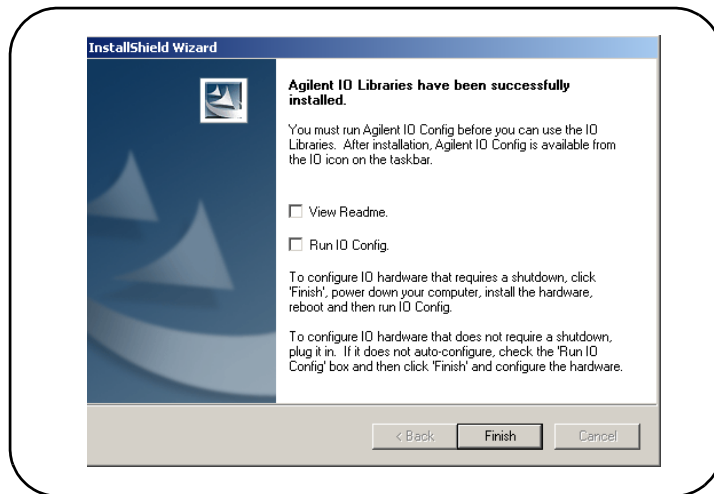

- 10** Click **Finish** to complete the full installation of the Agilent IO Libraries. If you checked the **View Readme** box, the Agilent IO Libraries Readme file is also displayed.
- 11** Remove the *Agilent IO Libraries for Instrument Control* CD from the CD-ROM drive.



---

## Installing Custom Agilent IO Libraries

This section shows steps to perform a Custom Installation of the Agilent IO Libraries. To perform a Full Installation, see *Chapter 1 - Installing the Agilent IO Libraries*. To perform a Runtime Installation of the libraries, see “Installing Runtime IO Libraries” in this chapter.

- 1 Turn the PC ON and, as required, install application software such as C/C++, VEE, etc. on your PC.
- 2 Insert the *Agilent IO Libraries for Instrument Control* CD into the CD-ROM drive and wait a few seconds for the application to run. The installer should automatically start when the CD is inserted. If not, select **Start | Run** and type `<drive>:setup.exe`, where *drive* is your CD-ROM drive.
- 3 The InstallShield® Wizard appears to begin IO Libraries installation.

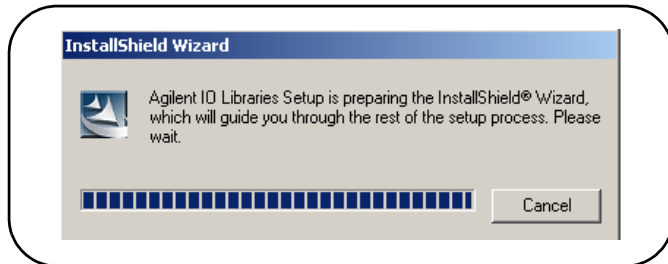

- 4 After a few seconds, the **Title Screen** appears.

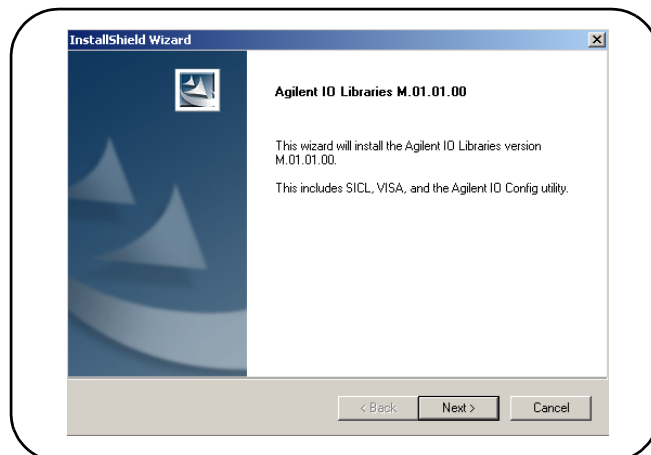

## Using the Agilent IO Libraries

### Installing Custom Agilent IO Libraries

- From the **Title Screen**, click **Next>** to go to the **License Agreement** screen and then click **Yes** to accept the license terms and to display the **Readme Information** screen.

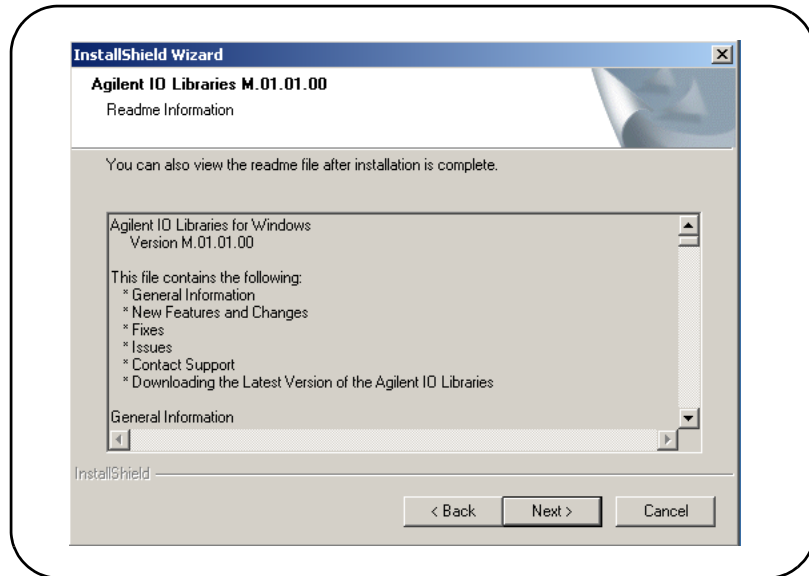

- Scroll through the **Readme Information** screen to display the latest Agilent IO Libraries information.
  - We highly recommend you read the **Readme Information** screen for the latest installation information before proceeding further with the installation.
  - If you do not want to read the **Readme Information** screen at this time, after the Agilent IO Libraries are installed you can view the Readme information by clicking the blue IO icon on the Windows taskbar and then clicking **View Documentation | IO Libraries Readme**
- When finished with the **Readme Information** screen, click **Next>** to display the **Select the Installation Option** screen. Click the **Custom Installation** box and then click **Next>** to display the **SICL Installation Directory** screen.

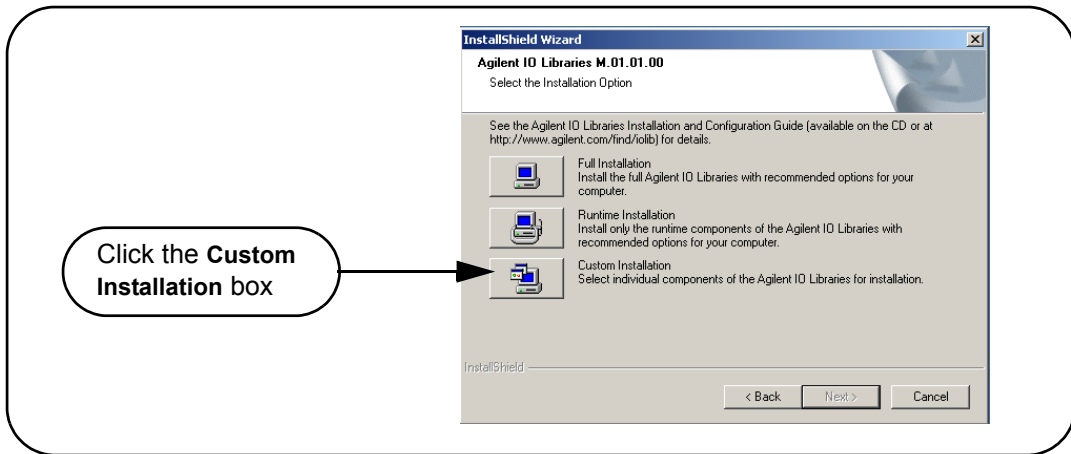

- 8 By default, SICL is installed in C:\Program Files\Agilent\IO Libraries. Click **Next>** to accept the default setting, or set the directory you want and then click **Next>** to display the **VISA installation directory** screen.
- 9 By default, VISA is installed in C:\Program Files\VISA. Click **Next>** to accept the default setting, or set the directory you want and then click **Next>** to display the **Select Type of Installation** screen.

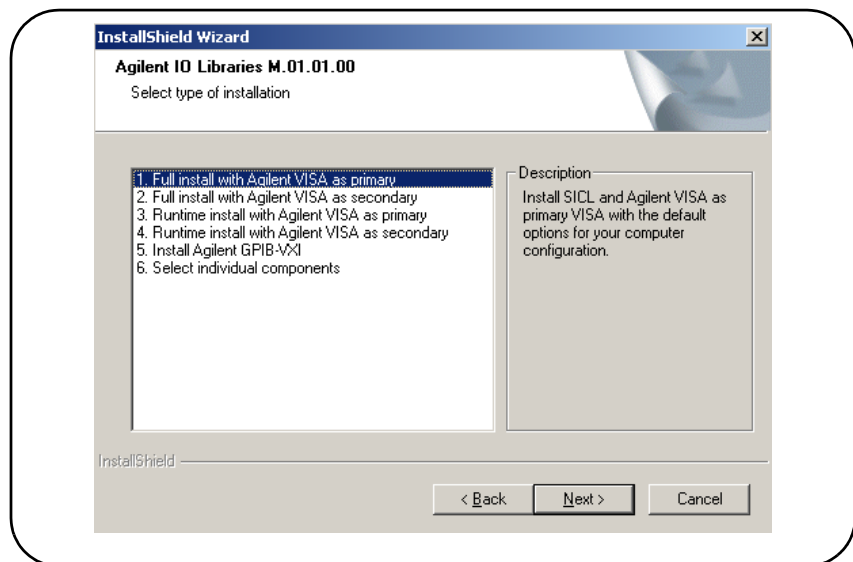

Using the Agilent IO Libraries  
**Installing Custom Agilent IO Libraries**

- 10** Use the following table for guidelines to select the type of installation for your application. Highlight your selection and then click **Next>** to install the option (1 - 6) selected.

Option	Description
<p><b>1. Full install with Agilent VISA as primary</b> (see Step 11)</p>	<p>Installs SICL and Agilent VISA as primary VISA with the default options for your computer configuration. If another vendor's VISA is installed, installing this option <b>will overwrite</b> the other vendor's VISA.</p>
<p><b>2. Full install with Agilent VISA as secondary</b> (see Step 11)</p>	<p>Installs SICL and Agilent VISA as secondary VISA (side-by-side) with the default options for your computer configuration. If another vendor's VISA is installed, installing this option <b>will not overwrite</b> the other vendor's VISA.</p> <p>Normal VISA programs use <i>visa32.dll</i> which is installed in the Windows system directory. Agilent VISA is implemented in <i>agvisa32.dll</i> which is also installed in the Windows system directory. If Agilent VISA is installed as the primary VISA, the Agilent version of <i>visa32.dll</i> is installed in the Windows system directory and forwards all VISA calls to <i>agvisa32.dll</i>.</p> <p>If Agilent VISA is installed as a secondary VISA, <i>agvisa32.dll</i> is installed but Agilent's <i>visa32.dll</i> is not installed. Thus, Agilent VISA will not overwrite another vendor's <i>visa32.dll</i> which may already be installed.</p> <p>If Agilent VISA is installed as a secondary VISA, the support files in the 'bin', 'include' and 'lib' directories of the &lt;VISA Path&gt; (e.g., C:\program files\visa\winnt on Window NT/2000 or C:\program files\visa\win95 on Windows 95/98/Me/2000/XP) are not installed since they would overwrite another vendor's support files.</p> <p>Copies of the Agilent version of the VISA support files are in the 'agbin', 'include' and 'lib' subdirectories under &lt;VISA Path&gt;\agvisa. These files are installed even when Agilent VISA is the primary VISA. The Agilent VISA utilities <i>vifind32.exe</i> and <i>VISA Assistant</i> use Agilent VISA even if another vendor's VISA is installed as primary VISA.</p> <p>Normally, a VISA program will use the primary VISA (i.e., call through <i>visa32.dll</i>). However, if a VISA program is linked with <i>agvisa32.lib</i> or dynamically loads <i>agvisa32.dll</i>, the program will use Agilent VISA even if it is not the primary VISA.</p>

Option	Description
<b>3. Runtime install with Agilent VISA as primary</b> (see Step 11)	Install SICL and Agilent VISA as primary VISA with runtime (not program development) support for ASRL (RS-232), TCP/IP (LAN Client), GPIB, and USB interfaces. If another vendor's VISA is installed, installing this option <b>will not overwrite</b> the other vendor's VISA.
<b>4. Runtime install with Agilent VISA as secondary</b> (see Step 11)	Install SICL and Agilent VISA as secondary VISA (side-by-side) with runtime (not program development) support for ASRL (RS-232), TCP/IP (LAN Client), GPIB, and USB interfaces. If another vendor's VISA is installed, installing this option <b>will not overwrite</b> another vendor's VISA.
<b>5. Install Agilent GPIB-VXI</b> (see Step 11)	Install GPIB-VXI support for Agilent and Hewlett-Packard VXI Command Modules on another vendor's VISA. Neither SICL nor Agilent VISA are installed.
<b>6. Select Individual Components</b> (see Step 12)	Allows you to install individually selected components of the IO Libraries, including SICL, VISA, E8491, I-SCPI, and GPIB-VXI Support components. I-SCPI is supplied for backward compatibility but is <b>not recommended</b> for new applications.

**11 Installation Steps for Options 1 - 5.** Use this step when you select Options 1 through 5. Skip this step and go to Step 12 when you select Option 6.

- a** From the **Select Type of Installation** screen, select Option 1, 2, 3, 4, or 5 and then click **Next>**.
- b** The **Current Settings** dialog box appears. This box shows the (default) paths in which SICL and VISA will be installed and the components that will be installed for the option selected. For example, the following figure shows the **Current Settings** dialog box when Option 1 is selected.

## Using the Agilent IO Libraries

### Installing Custom Agilent IO Libraries

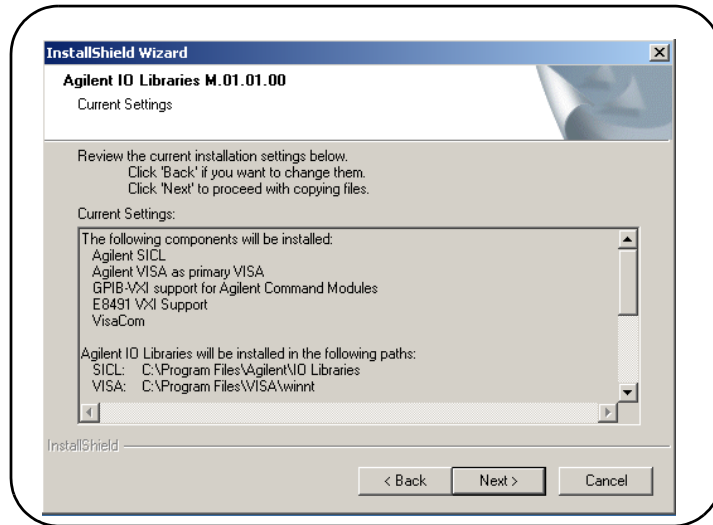

- **To Accept the Settings.** Click **Next>**. Setup will then install the files and display the **Agilent IO Libraries have been successfully installed** screen (see Step 13).
- **To Change the VISA Installation Path.** Click **<Back** on the **Current Settings** screen and **<Back** on the **Select Type of Installation** screen to display the **VISA Installation Directory** screen. Change the path as desired and then click **Next>**.
- **To Change the SICL Installation Path.** Click **<Back** on the **Current Settings** screen and **<Back** on the **Select Type of Installation** screen to display the **VISA Installation Directory** screen. Then, click **<Back** on the **VISA Installation Directory** screen to display the **SICL Installation Directory** screen. Change the path as desired and then click **Next>**.
- **To Change the IO Libraries Components to be installed.** Click **<Back** to re-display the **Select Type of Installation** screen. From this screen, select the **6. Choose Individual Components** box and then click **Next>** to proceed with a custom installation. See Step 12 for installation guidelines.

## 12 Option 6. Select Individual Components

- a From the **Select Type of Installation** screen, select **6. Select Individual Components** and then click **Next>** to display the **Select Individual Components** dialog box.

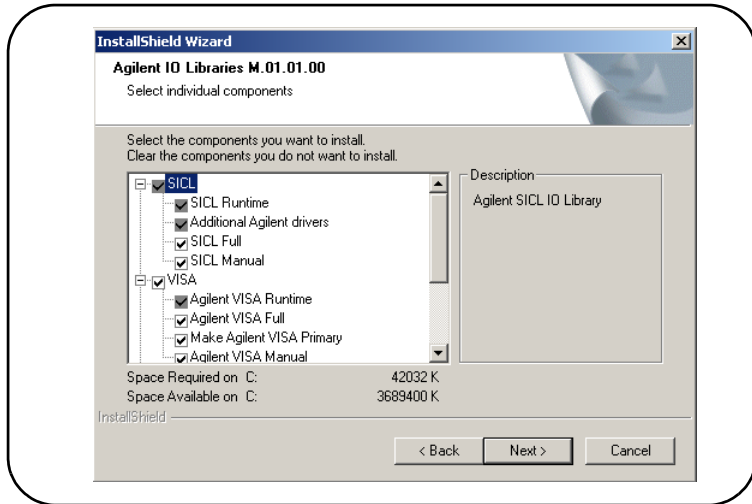

- b Select the components you want to install and clear the components you do not want to install. Then, click **Next>** to display the **Current Settings** dialog box. This box shows the (default) paths in which VISA and SICL will be installed and the components that will be installed.

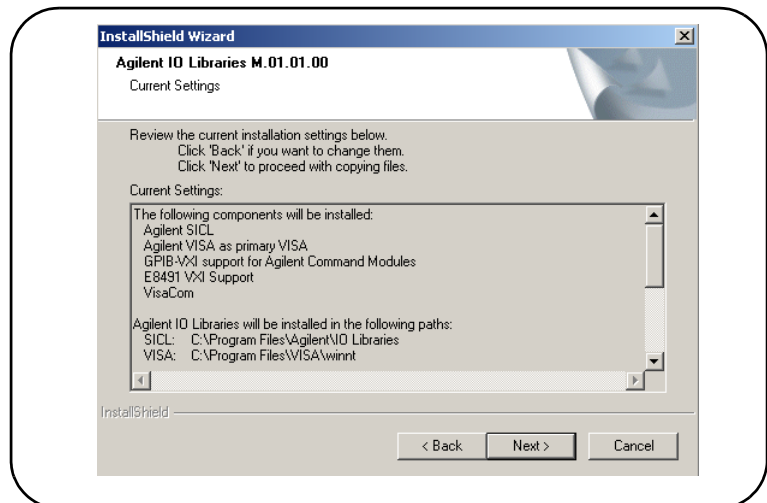

## Using the Agilent IO Libraries

### Installing Custom Agilent IO Libraries

- **To Accept the Settings.** Click **Next>**. Setup will then install the files and display the **Agilent IO Libraries have been successfully installed** screen (see Step 13).
  - **To Change the VISA Installation Path.** Click **<Back** on the **Current Settings** screen and **<Back** on the **Select Type of Installation** screen to display the **VISA Installation Directory** screen. Change the path as desired and then click **Next>**.
  - **To Change the SIDL Installation Path.** Click **<Back** on the **Current Settings** screen and **<Back** on the **Select Type of Installation** screen to display the **VISA Installation Directory** screen. Then, click **<Back** on the **VISA Installation Directory** screen to display the **SIDL Installation Directory** screen. Change the path as desired and then click **Next>**.
  - **To Change the IO Libraries Components to be installed.** Click **<Back** to re-display the **Select Individual Components** screen. Change the components to be installed and then click **Next>**.
- 13** As the last step in the Agilent IO Libraries installation, the **Agilent IO Libraries have been successfully installed** screen appears. For 82357A installation, do NOT check the **Run IO Config** box. (If desired, you can check the **View Readme** box.)

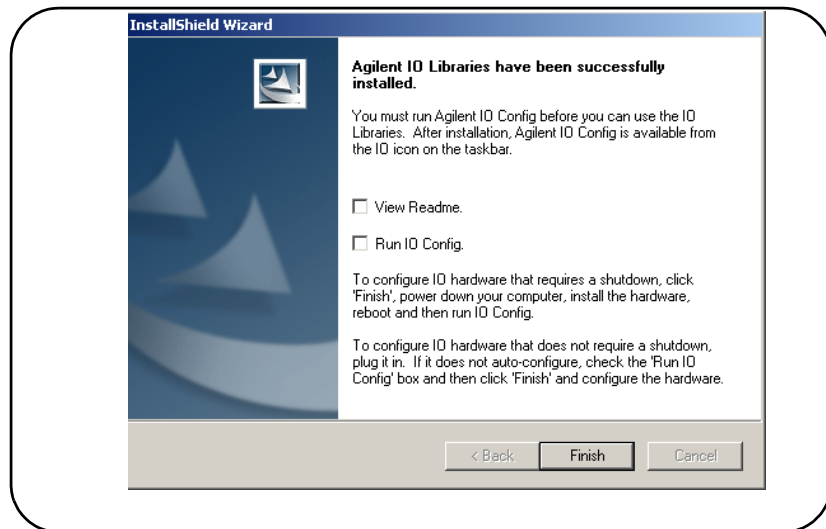



- 14** Click **Finish** to complete the custom installation of the Agilent IO Libraries. If you checked the **View Readme** box, the Agilent IO Libraries Readme file is also displayed.
- 15** Remove the *Agilent IO Libraries for Instrument Control* CD from the CD-ROM drive.

**Notes:**

---

## A

- Agilent IO Libraries
  - CD, using, 75
  - components, 71
  - Instrument Control CD, 14
  - verifying installation, 51

- Agilent
  - telephone numbers, 58
  - web site, 55, 58

## C

- changing configuration parameters, 41
- changing modes of operation, 42
- checking
  - IO Control operation, 54
  - PC, 49
  - USB cables, 49
  - USB interface, 49
  - USB scanner, 55
  - shipment, 8
- compliance, IEEE, 68
- configuration parameters, changing, 41
- configuration parameters, setting, 41
- connecting 82357A to PC, 16
- connecting 82357A to USB hub, 17
- copyright information, 63
- custom configuration, setting, 25

## D

- Declaration of Conformity, 63
- default configuration, setting, 23
- device manager, checking, 50

## E

- examples
  - IO Interface Configuration, 32

## H

- hardware checks, 49
- hardware description, 15
- high-performance operation, setting, 43

## I

- initial operating states, 37
- installation type, 84
- installing the 82357A
  - before you install, 8
  - configuring the 82357A, 23
  - connecting GPIB instruments, 28
  - connecting the 82357A, 15
  - installing IO Libraries, 10
  - programming via 82357A, 30
  - steps to install, 7
- Interface Name, 32
- IO Config, 71
- IO Control operation, checking, 54
- IO interface, 32
- IO Libraries
  - control icon, 72
  - checking for installation, 10
  - installation type, 84
  - installing custom libraries, 81
  - program groups created, 74
- iopen, 32

## L

- LED states, 37
- Logical Unit Number, 32

## M

- maximum system configuration, 68
- modes of operation, changing, 42
- multiple 82357A operation, 40
- multiple mode of operation, 38

## P

PC  
  checking, 49  
  power management, 51  
  rebooting, 49  
  suspend, 51  
printing history, 63  
program groups created, 74  
programming GPIB instruments, 31

## R

rebooting the PC, 49  
restricted rights, 62

## S

service and support, 58  
service information, 58  
setting  
  configuration parameters, 41  
  custom configuration, 25  
  default configuration, 23  
  high-performance operation, 43  
  timeout floor values, 42  
single 82357A operation, 39  
single mode of operation, 38  
software configuration checks, 54  
software installation checks, 51  
specifications, 67  
SRQ operation, 40  
SRQ performance, 68  
supplementary information, 68  
suspend/resume operation, 51  
system requirements, checking, 9

## T

T1 delay, default, 68  
telephone numbers, Agilent, 58  
timeout floor values, setting, 42  
trademark information, 63  
troubleshooting  
  check device manager, 50  
  flowchart, 47  
  hardware checks, 49  
  overview, 46  
  software configuration checks, 54  
  software installation checks, 51  
  suspend/resume operation, 51

## U

USB cables, checking, 49  
USB driver installation, verifying, 53  
USB interface, checking, 49  
USB scanner, checking, 55  
usbscan driver, assigning to 82357A, 57  
usbscan.sys, 9  
usbscan.sys, checking, 56  
using the 82357A, 36  
using the Agilent IO Libraries, 70

## V

viOpen, 32  
VISA Assistant, 30, 71  
VISA COM I/O, 71

## W

warranty, 62  
web site, Agilent, 58  
Windows plug and play manager, 19





Agilent Technologies, Inc.  
Printed in Malaysia  
May 2004 E0504



**User's Guide**

**82357-90001**